

REINFORCEMENT FOR CONCRETE— MATERIALS AND APPLICATIONS

Developed by Committee E-701,
Materials for Concrete Construction

Charles K. Nmai, Chairman David M. Suchorski, Secretary

Leonard W. Bell	Tarek S. Khan	Kenneth B. Rear
Richard P. Bohan	Paul D. Krauss	Raymundo Rivera-Villarreal
David A. Burg	Colin L. Lobo	Jere H. Rose
Darrell F. Elliot	Stella Lucie Marusin	Paul J. Tikalsky
James Ernzen	Patrick L. McDowell	Mark E. Vincent
James A. Farny	Gerald R. Murphy	Christopher H. Wright
Jose Pablo Garcia	Anthony C. Powers*	Kari L. Yuers
Morris Huffman		Robert C. Zellers

*Subcommittee Chairman.

CONTENTS

Preface, p. E2-2

Chapter 1—Introduction, p. E2-2

1.1—Definitions

Chapter 2—Structural concrete: Plain, reinforced, and prestressed, p. E2-3

2.1—Plain concrete

2.2—Reinforced concrete

2.2.1—Bending and bending stresses in reinforced concrete members

2.2.2—Other reinforcement applications

2.3—Prestressed concrete

2.3.1—Bending and bending stresses in prestressed concrete members

2.3.2—Advantages of prestressed concrete

2.3.3—Pretensioned and post-tensioned concrete

2.4—Other prestressing applications

Chapter 3—Reinforcing materials, p. E2-6

3.1—Steel reinforcement

3.1.1—Deformed steel bars

3.1.2—Threaded steel bars

3.1.3—Welded wire fabric

3.2—Fiber-reinforced polymer (FRP) bars

3.2.1—FRP materials

3.3—Fiber reinforcement

3.3.1—Applications

3.3.2—Steel fibers

3.3.3—Synthetic fibers

3.4—Materials for repair and strengthening of structural concrete members

3.4.1—External steel reinforcement

3.4.2—FRP plates, sheets, and jackets

Chapter 4—Prestressing materials, p. E2-12

4.1—Steel

4.1.1—Seven-wire strand

4.1.2—Wire

4.1.3—Bars

4.2—FRP

4.2.1—Strength

4.2.2—Applied loads

Chapter 5—Corrosion-resistant reinforcement, p. E2-14

5.1—Epoxy coating

5.2—Galvanizing

5.3—Stainless steel

5.4—Chemical and mineral corrosion protection systems

The Institute is not responsible for the statements or opinions expressed in its publications. Institute publications are not able to nor intended to supplant individual training, responsibility, or judgment of the user, or the supplier of the information presented.

ACI Education Bulletin E2-00.

Copyright © 2000, American Concrete Institute.

All rights reserved including rights of reproduction and use in any form or by any means, including the making of copies by any photo process, or by electronic or mechanical device, printed, written, or oral, or recording for sound or visual reproduction or for use in any knowledge or retrieval system or device, unless permission in writing is obtained from the copyright proprietors. Printed in the United States of America.

Chapter 6—Storage and handling, p. E2-14

- 6.1—Uncoated steel reinforcement
- 6.2—Epoxy-coated steel reinforcement
- 6.3—FRP
- 6.4—Fiber reinforcement

Chapter 7—References, p. E2-15

PREFACE

This document is an introductory document on the topic of commonly used materials for reinforcement of concrete. This primer describes the basic properties and uses of these materials. It is targeted at those in the concrete industry not involved in designing with or specifying these materials. Students, craftsman, inspectors, and contractors may find this a valuable introduction to a complex topic. The document is not intended to be a state-of-the-art report, user's guide, or a technical discussion of past and present research findings on the subject. More detailed information is available in ACI Committee Reports listed in Chapter 7, References.

CHAPTER 1—INTRODUCTION

Nearly everyone involved in construction knows that reinforcement is often used in concrete. However, why it is used and how it is used are not always well understood.

This bulletin provides some of the information important to understanding why reinforcement is placed in concrete. Most concrete used for construction is a combination of concrete and reinforcement that is called reinforced concrete. Steel is the most common material used as reinforcement, but other materials such as fiber-reinforced polymer (FRP) are also used. The reinforcement must be of the right kind, of the right amount, and in the right place in order for the concrete structure to meet its requirements for strength and serviceability.

In this document, frequent references are made to standards of the American Society for Testing and Materials (ASTM). These include test methods, definitions, classifications, and specifications that have been formally adopted by ASTM. New editions of the *ASTM Book of Standards* are issued annually and all references to these standards in this bulletin refer to the most recent edition. Other agencies have similar or additional standards that may be applicable.

1.1—Definitions

Certain terms will be used throughout this bulletin with which familiarity is important. A few of the more common and most frequently used are listed in this section. Precise technical definitions may be found in ACI 116R, "Cement and Concrete Terminology."

bar size number—a number used to designate the bar size. Reinforcing bars are manufactured in both International System (SI—commonly known as metric—measured in millimeters), and U.S. customary (in.-lb) sizes. The bar number for metric bar sizes denotes the approximate diameter of the bar in millimeters. For example, a No. 13 bar is about 13 mm in diameter (actually 12.7 mm). U.S. customary bar sizes No. 3 through No. 8 have similar designations, the bar number

denoting the approximate diameter in eighths of an inch (for example, a No. 5 bar is about 5/8 in. in diameter).

bent bar—a reinforcing bar bent to a prescribed shape, such as a straight bar with a hooked end.

compression—a state in which an object is subject to loads that tend to crush or shorten it.

compression bar—a reinforcing bar used to resist compression forces.

compressive strength—a measure of the ability of the concrete to withstand crushing loads.

elastic limit—the limit to which a material can be stressed (stretched or shortened axially) and still return to its original length when unloaded. Loads below the elastic limit result in the material being deformed in proportion to the load. Material stretched beyond the elastic limit will continue to deform under a constant, or even declining, load.

fibrillated fibers—synthetic fibers used to reinforce concrete that are bundled in a mesh resembling a miniature fish net.

FRP reinforcement—reinforcing bars, wires or strand made from fiber-reinforced polymer (FRP). (Originally, the "p" in FRP stood for "plastic," but "polymer" is now the preferred term to avoid confusion.)

monofilament fibers—discrete individual fibers used to reinforce concrete.

post-tensioning—a method of prestressing in which the tendons are tensioned after the concrete is hardened.

prestressed concrete—Structural concrete in which internal stresses (usually compressive stresses) have been introduced to reduce potential tensile stresses in the concrete resulting from loads. This introduction of internal stresses is referred to as *prestressing* and is usually accomplished through the use of tendons that are tensioned or pulled tight prior to being anchored to the concrete.

pretensioning—a method of prestressing in which the tendons are tensioned before concrete is hardened.

rebar—an abbreviated term for reinforcing bar.

reinforced concrete—structural concrete with at least a code-prescribed minimum amount of prestressed or nonprestressed reinforcement. Fiber-reinforced concrete is not considered *reinforced concrete* according to this definition.

secondary reinforcement—nonstructural reinforcement such as welded wire fabric, fibers, or bars to minimize crack widths that are caused by thermal expansion and contraction, or shrinkage. Secondary reinforcement is reinforcement used to hold the concrete together after it cracks. Structural concrete with only secondary reinforcement is not considered reinforced concrete.

steel fibers—carbon or stainless steel fibers used in fiber-reinforced concrete meeting the requirements of ASTM A 820.

structural concrete—all concrete used for structural purposes including plain and reinforced concrete.

tendon—a wire, cable, bar, rod, or strand, or a bundle of such elements, used to impart prestress to concrete. Tendons are usually made from high-strength steel, but can also be made from such materials as FRP.

tensile strength—a measure of the ability of a material (for example, concrete or reinforcement) to withstand tension.

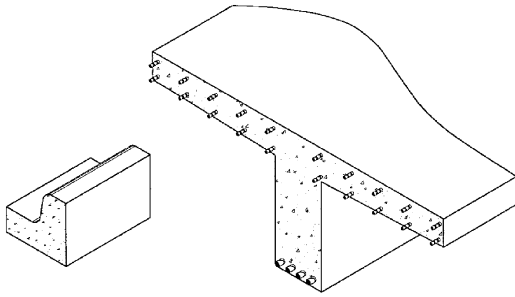

Fig. 2.2—Examples of plain and reinforced concrete: plain curb and gutter (left) and reinforced concrete T-beam (right).

Tension in both the concrete and reinforcement results when reinforced concrete bends under loading.

tension—a state in which a material is subject to loads that tend to stretch or lengthen it.

yield strength—The stress required to stretch a material to its elastic limit.

CHAPTER 2—STRUCTURAL CONCRETE: PLAIN, REINFORCED, AND PRESTRESSED

The design and construction of structural concrete, both plain and reinforced (including nonprestressed and prestressed concrete) is covered by ACI 318, Building Code Requirements for Structural Concrete, and ACI 301, Standards Specification for Structural Concrete.

2.1—Plain concrete

Plain concrete is structural concrete without reinforcement or with less than the minimum amount required by ACI 318 for reinforced concrete. It is sometimes used in slabs-on-grade, pavement, basement walls, small foundations, and curb-and-gutter.

2.2—Reinforced concrete

Plain concrete (Fig. 2.2) has compressive strength—the ability to resist crushing loads; however, its tensile strength is only about 10% of its compressive strength. Its tensile strength is so low that it is nearly disregarded in design of most concrete structures. Reinforced concrete is a combination of adequate reinforcement (usually steel bars with raised lugs called deformations) and concrete designed to work together to resist applied loads (Fig. 2.2). Properly placed reinforcement in concrete improves its compressive and tensile strength.

2.2.1 Bending and bending stresses in reinforced concrete members—Many structural members are required to carry loads that cause bending stresses. An example is a simply-supported beam, in which the top of the member is subjected to compression lengthwise while the bottom is subjected to tension lengthwise (Fig. 2.2.1(a)). This is referred to as beam action and can be illustrated by supporting a board at each end and breaking it by applying a heavy load to the center. If the board is loaded at each end and supported in the middle, as in a cantilevered beam, the top of the board over the support is in tension and the bottom is in compression (Fig. 2.2.1(b)). Unreinforced concrete structural members have little capacity for beam action because concrete's low tensile

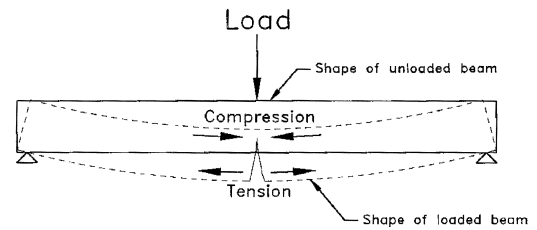

Fig. 2.2.1(a)—A simple beam loaded in the middle and supported at the ends will tend to deflect or bend down in the middle, causing tensile stress in the bottom of the beam and tending to pull it apart. That is, the bottom of the beam is in tension. Reinforcing steel near the bottom of the beam will resist this tension and hold it together.

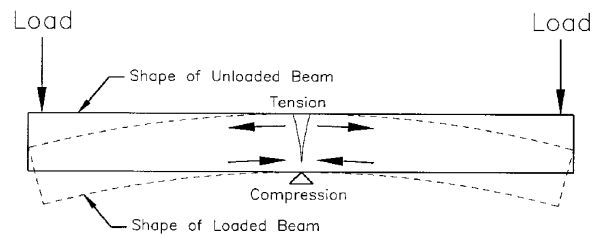

Fig. 2.2.1(b)—If the beam is supported in the middle and the ends are loaded (as in a cantilever beam, such as a balcony), the top of the beam over the support is in tension and will pull apart or crack if there is no reinforcing steel near the top of the beam.

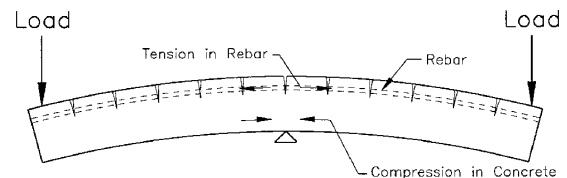

Fig. 2.2.1(c)—Properly placed reinforcement in this cantilever beam will resist tension and control cracking.

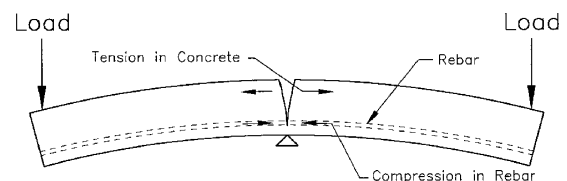

Fig. 2.2.1(d)—Incorrectly placed or missing reinforcement is not effective in resisting tension and will allow uncontrolled cracking in the beam.

strength provides little resistance to the tensile stress in the tension side of the member. This is one of the most important functions of reinforcement in concrete members—to resist the tension in these members due to beam action (Fig. 2.2.1(c)). Steel is remarkably well-suited for concrete reinforcement because it has high tensile strength, and therefore relatively small amounts are required. Also, concrete bonds to steel, and both expand and contract to about the same degree with temperature changes. The good bond between concrete and steel allows an effective transfer of stress or load between the steel and concrete so both materials act together in resisting beam action. For these reasons, steel is the most

common material used to reinforce concrete. However, other materials such as FRP are also used for reinforcement.

Many structural members must perform like a beam to fulfill their function in the structure. Among such concrete structural members are beams, girders, joists, structural slabs of all kinds, some columns, walls that must resist lateral loads,

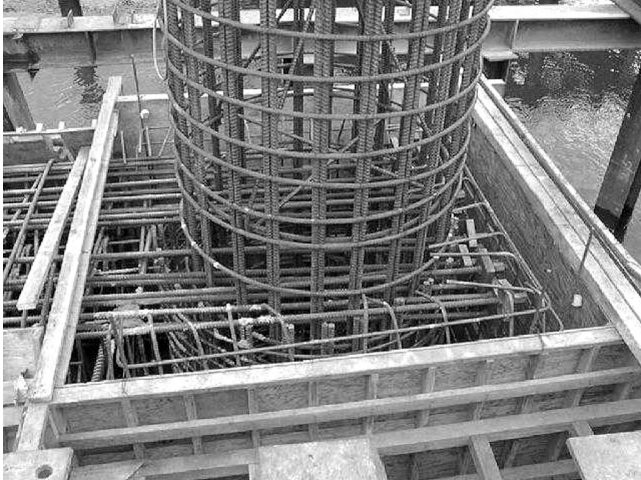

Fig. 2.2.2(a)—Reinforcement in a concrete column (courtesy of HDR Engineering, Inc.).

and more complex members such as folded plates, arches, barrels, and domes. In addition to unintentional omission of part or all of the reinforcement, improper placement of the reinforcement designed to resist tension is one of the most common causes of structural concrete failures (Fig. 2.2.1(d)). If the tensile steel is not properly placed in the tension zone of a structural member, it will not be effective in resisting tension, and failure may occur.

2.2.2 Other reinforcement applications—In addition to its use to resist tension in structural members, reinforcement is used in concrete construction for other reasons, such as:

- To resist a portion of the compression force in a member. The compressive strength of steel reinforcement is about 20 times greater than that of normal-strength concrete. In a column, steel is sometimes used to reduce the size of the column or to increase the column's carrying capacity (Fig. 2.2.2(a)). Compression steel is sometimes used in beams for the same reasons.
- To resist diagonal tension or shear in beams, walls, and columns. Reinforcement used to resist shear in beams is commonly in the form of *stirrups* (Fig 2.2.2(b)), but may also consist of longitudinal reinforcement bent up at an angle near the ends of the beam, or welded wire fabric. In columns, shear reinforcement is typically in the form of ties, hoops, or spirals.



Fig. 2.2.2(b)—Stirrups to resist shear in a concrete box girder bridge (courtesy HDR Engineering, Inc.).



Fig. 2.2.2(c)—Hoop reinforcement in a reinforced concrete column (courtesy of HDR Engineering, Inc.).

- To resist bursting stresses resulting from high compressive loads in columns or similar members, in which spiral steel reinforcement, hoops (Fig. 2.2.2(c)), or ties are used.
- To resist internal pressures in round structures such as circular tanks, pipes, and bins.
- To minimize cracking, or more precisely, to promote numerous small cracks in place of fewer large cracks, in concrete members and structures.
- To limit widths and control spacing of cracks due to stresses induced by temperature changes and shrinkage (shortening of the concrete due to drying over time) in slabs and pavement.

2.3—Prestressed concrete

Prestressed concrete is structural concrete in which internal stresses have been introduced to reduce potential tensile stresses in the concrete resulting from loads. This introduction of internal stresses is called *prestressing* and is usually accomplished through the use of tendons that are tensioned or pulled tight prior to being anchored to the concrete. Tendons can consist of strands, wires, cables, bars, rods, or bundles of such elements. Tendons are usually made from high-strength steel, but can also be made from other materials such as FRP.

2.3.1 Bending and bending stresses in prestressed concrete members—As with reinforced concrete members, the most common type of prestressed members are bending members or beams. The tendons in prestressed concrete beams, like the nonprestressed reinforcement in reinforced concrete beams, are placed near the top or bottom of the beam where the applied loads will cause tension. For example, in a beam spanning between two supports carrying a load in the middle, the load would cause tension at the bottom of the beam, so the tendons would be placed near the bottom of the beam to resist this tension (Fig. 2.3.1). Similarly, in a beam supported at the center and loaded at the ends, the loads would cause tension on the top part of the beam, so the tendons would be placed near the top of the beam to resist this tension. The difference between the reinforced concrete beams and the prestressed concrete beams in these examples is that, in the nonprestressed

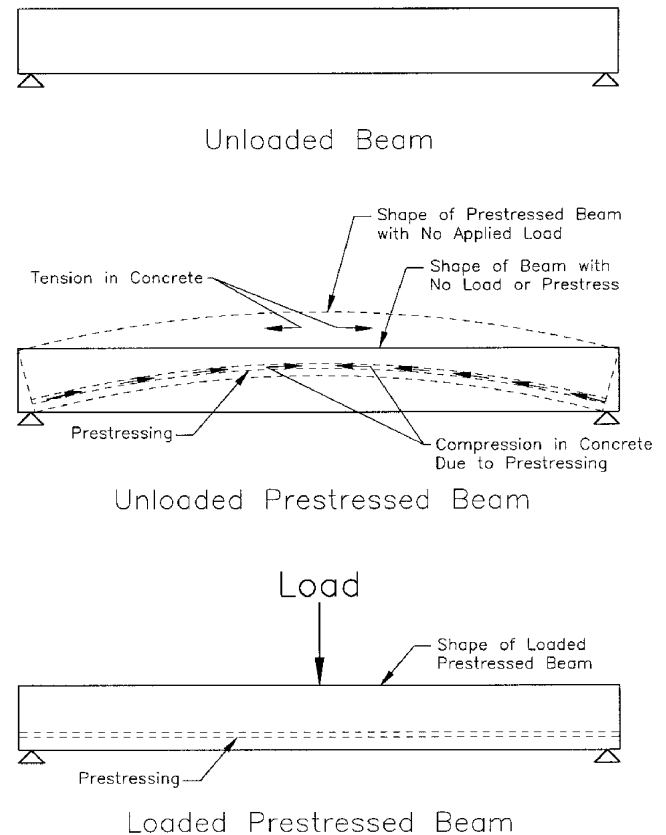

Fig. 2.3.1—In a prestressed simple beam, the prestressing steel is placed near the bottom of the beam, just like regular reinforcing steel. But in the prestressed beam, the prestressing causes the unloaded beam to bend upward in the middle, opposite to the downward bending caused by the applied load. The combined effect is a beam that bends less, and therefore cracks less, under load.

beams, the reinforcement is not subjected to tension until the beam is loaded, whereas in the prestressed beam, the tendons are tensioned before the beam is loaded. By tensioning the tendons before loading the beam, the concrete on the side of the beam with the tendons is squeezed or compressed. When the beam is loaded, the tension in the concrete caused by the load is offset by the compression caused by the prestress.

2.3.2 Advantages of prestressed concrete—There are several benefits to prestressing concrete:

- Prestressed beams make more efficient use of the best qualities of the concrete and tendons (that is, the compressive strength of concrete and the tensile strength of steel). Therefore, a prestressed beam using a given amount of concrete can be made stronger than a comparable reinforced concrete beam.
- A prestressed concrete beam can be designed such that the cracks in the concrete due to applied loads are smaller than in a comparable reinforced concrete beam, or can be virtually eliminated. This makes for a more durable, longer lasting member by preventing water, chlorides (deicing salt), and other corrosive materials from coming into contact with the tendons.

- Prestressed beams, particularly pretensioned ones, are frequently made in a factory and shipped to the construction site. The quality of the formwork and concrete, and the placement of the prestressed and nonprestressed reinforcement, can be better controlled in a factory setting than at the construction site, resulting in a higher-quality structure.

2.3.3 Pretensioned and post-tensioned concrete—Concrete is prestressed by one of two general methods: *pretensioning* and *post-tensioning*. When concrete is pretensioned, the tendons are stressed in the form before concrete is placed. When concrete is post-tensioned, the tendons are stressed after concrete is hardened.

2.3.3.1 Pretensioned concrete—Pretensioning is usually performed in a factory (or precasting yard). The tendons are held in place and tensioned against the ends of the casting bed before the concrete is placed. Because the tensile force in the tendons is very high, very strong temporary anchorages are needed; these would be difficult to provide at a construction site. After the concrete has achieved adequate strength, the temporary anchorages are released, or the tendons are cut outside of the concrete, transferring the prestress force from the ends of the casting bed to the concrete. In pretensioned beams, the tendons usually consist of seven-wire strands that, after release of the temporary anchorages, are anchored by bond to the concrete. Advantages of pretensioned concrete are that it does not require the use of permanent anchorages and that the tendons are bonded to the concrete over their entire length.

2.3.3.2 Post-tensioned concrete—Post-tensioning is usually performed at the job site. Post-tensioning tendons are usually internal but can be external. Internal tendons are placed within plastic or metal ducts embedded in the concrete and tensioned against the hardened concrete. Internal tendons are usually bonded, but can be unbonded. After tensioning, bonded tendon ducts are filled with cement grout to prevent steel corrosion. Unbonded tendons are not grouted. External tendons are not necessarily placed in ducts, but are attached to the concrete only at the anchorages and at changes in direction (deviators). Post-tensioning requires special hardware at the ends of each tendon to anchor the tendon to the concrete. Nonprestressed reinforcement is usually required in the concrete behind the anchor plates to resist localized forces in this area, sometimes referred to as the anchorage zone.

Some of the advantages of post-tensioning are that it does not require the large temporary anchorages required for pretensioning, it allows exploitation of the flexibility inherent to cast-in-place concrete construction, and it allows for larger members than are possible in a precasting plant.

2.4—Other prestressing applications

In addition to its use to resist tension in bending members, prestressing is used in concrete construction for other functions, such as:

- To resist internal pressures in circular structures such as circular tanks, pipes, and bins.
- To limit cracking in bridge decks and slabs-on-grade.
- To improve capacity of columns and piles.
- To reduce long-term deflections.

CHAPTER 3—REINFORCING MATERIALS

Various materials are used to reinforce concrete. Round steel bars with deformations, also known as deformed bars, are the most common type of reinforcement. Others include steel welded wire fabric, fibers, and FRP bars. It is important to note that not all structural concrete containing reinforcement meets the ACI Building Code (ACI 318) definition of reinforced concrete.

3.1—Steel reinforcement

Steel reinforcement is available in the form of plain steel bars, deformed steel bars, cold-drawn wire, welded wire fabric, and deformed welded wire fabric. Reinforcing steel must conform to applicable ASTM standard specifications.

3.1.1 Deformed steel bars—Deformed bars are round steel bars with lugs, or deformations, rolled into the surface of the bar during manufacturing. These deformations create a mechanical bond between the concrete and steel. Deformed steel bars (Fig. 3.1.1) are the most common type of reinforcement used in structural concrete.

3.1.1.1 Deformed bar sizes—Deformed steel bars are designated in both SI (metric) and U.S. customary (in.-lb) sizes, according to ASTM A 615M/A 615, A 706M/A 706, and A 996M/A 996. In other words, metric bar sizes represent a *soft conversion* of U.S. customary bar sizes. Metric bars are exactly the same size as corresponding U.S. customary bars, but are given a metric designation (bar number and grade). The bar number for both metric and U.S. customary bar sizes denotes the approximate diameter of the bar in millimeters and eighths of an inch, respectively. (For U.S. customary bar sizes No. 4 through No. 8, the relationship between bar number and bar diameter in eighths of an inch is exact—the bar number is *exactly* the number of eighths of an inch in the bar diameter. However, for U.S. customary bar sizes No. 9 through No. 18, the bar number is the number of eighths of an inch in the diameter closest to the actual diameter.) For example, a No. 13 metric bar is approximately 13 mm in diameter and is exactly the same size as a No. 4 U.S. customary bar, which is 4/8 or 1/2 in. in diameter. Similarly, a No. 32 metric bar is approximately 32 mm in diameter and is exactly the same size as a No. 10 U.S. customary bar, which is 1.27 in. in diameter, or approximately 10/8 or 1-1/4 in. There are 11 bar sizes. The 11 metric sizes are No. 10, 13, 16, 19, 22, 25, 29, 32, 36, 43, and 57. The corresponding U.S. customary sizes are No. 3 through No. 11, No. 14, and No. 18. Note that the six metric bar sizes from No. 10 through No. 25 (corresponding to No. 3 through No. 8 U.S. customary bars) are in 3 mm (1/8 in.) increments and that the designation numbers for these bars are three times the bar

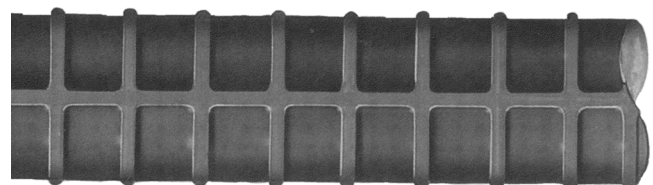

Fig. 3.1.1—Typical deformed reinforcing bar (courtesy of Concrete Reinforcing Steel Institute).

Table 3.1.1.2(a)—ASTM standard reinforcing bars

ASTM designation	Type	Metric grades	Metric sizes	U.S. customary grades	U.S. customary sizes
A 615M/A 615	Billet	300	10 - 19	40	3 - 6
		420	10 - 57	60	3 - 11, 14, 18
		520	19 - 57	75	6 - 11, 14, 18
A 706M/A 706	Low-alloy	420	10 - 57	60	3 - 11, 14, 18
A 996M/A 996	Rail	350	10 - 25	50	3 - 8
		420	10 - 25	60	3 - 8
A 996M/A 996	Axle	300	10 - 25	40	3 - 8
		420	10 - 25	60	3 - 8

Table 3.1.1.2(b)—Bar marks

Mark	Meaning
Symbol or series of symbols	Designates producer's mill
Number	Designates bar size
S, W, "rail symbol" or "rail symbol" and R, A	Designates type of steel (S - billet-steel, W - low-alloy steel, "rail symbol" or R - rail-steel, or A - axle steel)
Blank or number	Grade mark (blank for Grade 300/Grade 40 and Grade 350/Grade 50, otherwise the grade number).

number of their corresponding U.S. customary bar, plus one. Also note that there is a No. 10 bar in both U.S. customary and metric units, but the U.S. customary No. 10 bar is more than three times as large as the No. 10 metric bar.

3.1.1.2 Deformed bar grades and availability—Deformed steel bars are furnished in four metric strength grades of steel: 300, 350, 420, and 520, having minimum yield strengths of 300, 350, 420, and 520 MPa, respectively. The four corresponding U.S. customary grades: Grades 40, 50, 60, and 75, have minimum yield strengths of 40,000, 50,000, 60,000, and 75,000 psi, respectively. They are manufactured from four types of steel: billet steel (ASTM A 615M/A 615), low-alloy steel (ASTM A 706M/A 706), and rail and axle steel (ASTM A 996M/A 996).

Billet-steel bars are available in three metric grades and three equivalent U.S. customary grades. They are available in metric bar sizes No. 10 through No. 19 in Grade 300, in all bar sizes in Grade 420, and in bar sizes No. 19 through No. 57 in Grade 520 (Table 3.1.1.2(a)). Billet-steel bars are available in U.S. customary bar sizes No. 3 through No. 6 in Grade 40, in all bar sizes in Grade 60, and in bar sizes No. 6 through No. 18 in Grade 75.

Low-alloy-steel bars are manufactured in all sizes, but in only one metric grade (420) and one equivalent U.S. customary grade (60). Availability of ASTM standard metric and U.S. customary reinforcing bars is summarized in Table 3.1.1.2(a).

Rail-steel bars are manufactured by rolling used railroad rails, and are available in two metric grades (350 and 420) and two equivalent U.S. customary grades (50 and 60). They are available in metric bar sizes No. 10 through No. 25 and in U.S. customary bar sizes No. 3 through No. 8.

Axle-steel bars are manufactured by rolling used railroad car axles, and are available in two metric grades and two equivalent U.S. customary grades. They are available in metric bar sizes No. 10 through No. 25 in Grades 300 and 420

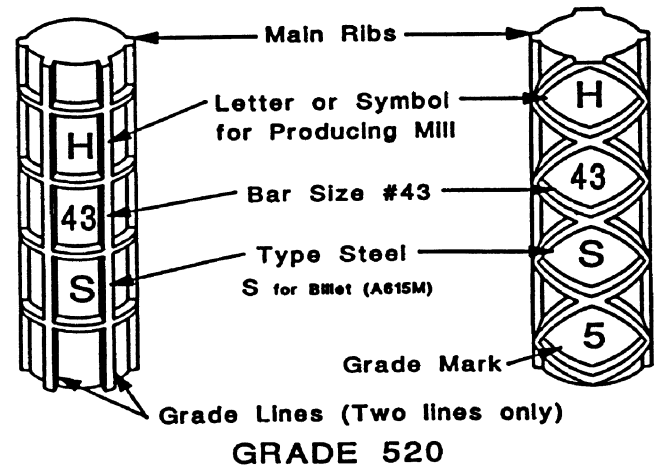
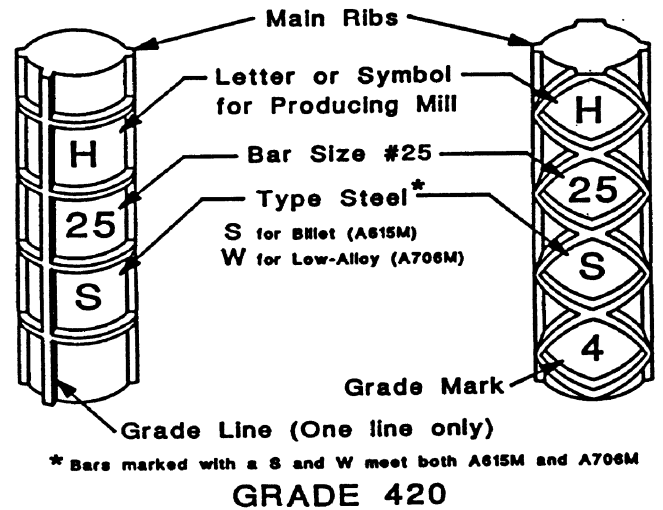

Fig. 3.1.1.2—Typical metric reinforcing bar identification markings (courtesy of Concrete Reinforcing Steel Institute).

and in U.S. customary bar sizes No. 3 through No. 8 in Grades 40 and 60.

All deformed steel bars are required to be marked with identifying symbols rolled into one side of each bar (Fig. 3.1.1.2). The symbols must consist of the information shown in Table 3.1.1.2(b), and can be oriented to read vertically or horizontally. As an alternate to rolling the grade mark number for Grade 420/Grade 60 or Grade 520/Grade 75, the grade can be designated by rolling an additional longitudinal rib or ribs on the bar (Fig. 3.1.1.2).

3.1.1.3 Cutting, bending, and welding—Reinforcing bars are cut and bent either in the fabricator's shop or at the job site, although it is preferable to do as much of this work as possible

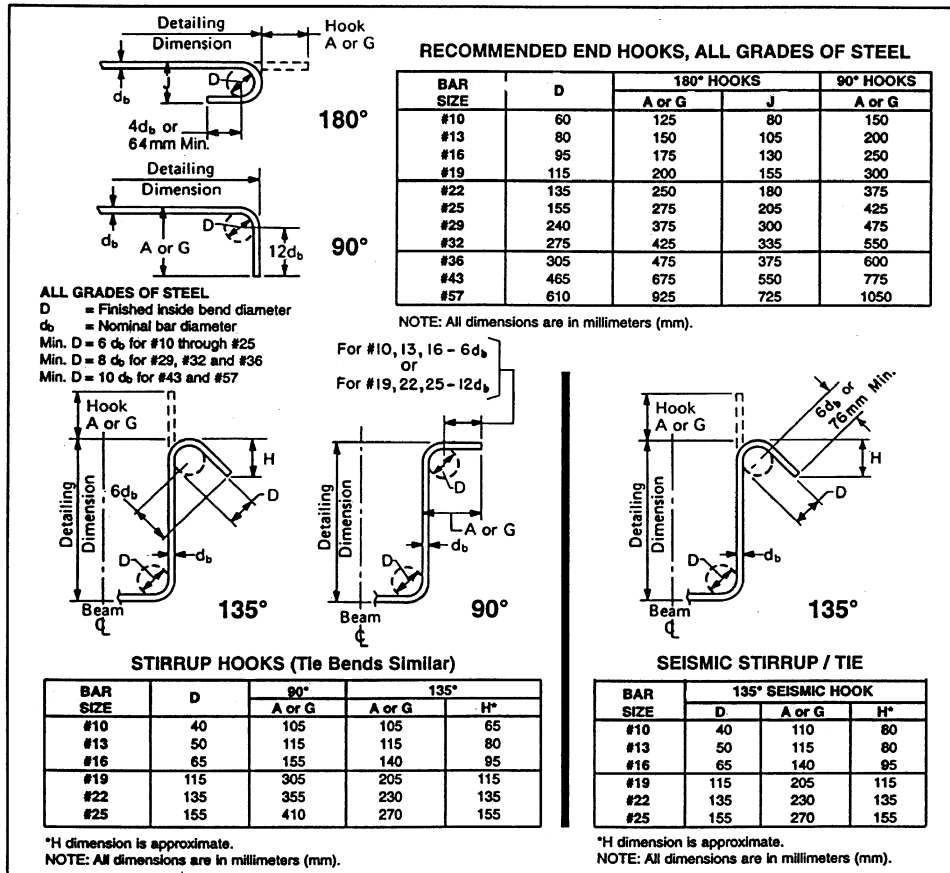

Fig. 3.1.1.3—Standard hook details for metric reinforcing bars (courtesy of Concrete Reinforcing Steel Institute).

Table 3.1.3—Common styles of welded wire fabric

Metric styles (MW = plain wire)	A _S , mm ² /m	Weight, kg/m ²	Equivalent, U.S. customary styles (W = plain wire)	A _S , in. ² /ft	Weight, lb/100 ft ²
102x102 – MW9xMW9	88.9	1.51	4x4 – W1.4xW1.4	0.042	31
102x102 – MW13xMW13	127.0	2.15	4x4 – W2.0xW2.0	0.060	44
102x102 – MW19xMW19	184.2	3.03	4x4 – W2.9xW2.9	0.087	62
102x102 – MW26xMW26	254.0	4.30	4x4 – W4.0xW4.0	0.120	88
152x152 – MW9xMW9	59.3	1.03	6x6 – W1.4xW1.4	0.028	21
152x152 – MW13xMW13	84.7	1.46	6x6 – W2.0xW2.0	0.040	30
152x152 – MW19xMW19	122.8	2.05	6x6 – W2.9xW2.9	0.058	42
152x152 – MW26xMW26	169.4	2.83	6x6 – W4.0xW4.0	0.080	58
102x102 – MW20xMW20	196.9	3.17	4x4 – W3.1xW3.1	0.093	65
152x152 – MW30xMW30	199.0	3.32	6x6 – W4.7xW4.7	0.094	68
305x305 – MW61xMW61	199.0	3.47	12x12 – W9.4xW9.4	0.094	71
305x305 – MW110xMW110	362.0	6.25	12x12 – W17.1xW17.1	0.171	128
152x152 – MW52xMW52	342.9	5.66	6x6 – W8.1xW8.1	0.162	116
152x152 – MW54xMW54	351.4	5.81	6x6 – W8.3xW8.3	0.166	119
305x305 – MW59xMW59	192.6	8.25	12x12 – W9.1xW9.1	0.091	69
305x305 – MW107xMW107	351.4	9.72	12x12 – W16.6xW16.6	0.166	125
152x152 – MW28xMW28	186.3	3.22	6x6 – W4.4xW4.4	0.088	63
152x152 – MW52xMW52	338.7	5.61	6x6 – W8xW8	0.160	115
305x305 – MW57xMW57	186.3	3.22	12x12 – W8.8xW8.8	0.088	66
305x305 – MW103xMW103	338.7	5.61	12x12 – W16xW16	0.160	120
152x152 – MW27xMW27	177.8	3.08	6x6 – W4.2xW4.2	0.084	60
152x152 – MW48xMW48	317.5	5.52	6x6 – W7.5xW7.5	0.150	108
305x305 – MW54xMW54	175.7	3.08	12x12 – W8.3xW8.3	0.083	63
305x305 – MW97xMW97	317.5	5.52	12x12 – W15xW15	0.150	113

in the fabricator's shop. Bars should be bent by machine. Bent bars are then checked to insure that lengths, depths, and radii are correctly reproduced, as shown on the bending details. There are many types of bends; the most common ones are illustrated in Fig. 3.1.1.3. The use of hand bending tools is limited to making adjustments during placing.

Reinforcing bars are usually cut to length by shearing, although sawing is required where compressive bars are to be spliced end-to-end. Cutting by burning with oxyacetylene equipment is discouraged. Heating of reinforcing bars for bending or straightening is permitted only when specifically approved by the engineer. Heating can change the characteristics of the steel. This can weaken the bars by making them brittle and dangerous to handle.

3.1.2 Threaded steel bars—Threaded steel bars are made by several manufacturers in Grade 420/Grade 60 conforming to ASTM A 615M/A 615, but are not available in all sizes. These bars can be spliced with threaded couplers or anchored through steel plates, while still providing continuous bond between the bar and concrete. They are used as an alternative to lapping standard deformed bars when long bar lengths are required and lap splices are impractical, or where bars need to be anchored close to the edge of a member.

3.1.3 Welded wire fabric—Welded wire fabric reinforcement (WWF), also known as welded wire reinforcement (Fig. 3.1.3), is a square or rectangular mesh of wires, factory-welded at all intersections. It is used for many applications such as to resist temperature and shrinkage cracks in slabs, as web stirrups in beams, and as tie reinforcement in columns. It is manufactured with either plain or deformed wire according to ASTM standards A 184M/A 184 (deformed steel bar mats), A 185 (plain steel welded wire fabric), A 497 (deformed steel welded wire fabric) or A 884M/A 884 (epoxy-coated steel wire and welded wire fabric). Welded wire fabric in which only the minimum amount of cross wire required for fabrication and handling is used is called "one-way" fabric. Where an appreciable amount of wire is provided crosswise (transversely) as well as lengthwise (longitudinally), it is called a "two-way" fabric. The lighter fabrics are shipped in rolls, while the heavier fabrics, generally 4.9 mm (No. 6 gage) wire and heavier, are shipped in flat sheets.

Metric wire fabric is usually designated as follows: WWF followed by the spacing of longitudinal and transverse wires in millimeters and then the areas of the individual longitudinal and transverse wires in square millimeters. Each wire area is preceded by the letters "MW" for plain wire reinforcement ("W" only for U.S. customary units) or "MD" for deformed wire reinforcement ("D" only for U.S. customary units). Common styles of both metric and U.S. customary welded wire reinforcement are listed in Table 3.1.3.

3.2—Fiber-reinforced polymer (FRP) bars

FRP bars are sometimes used as an alternative to steel deformed bars where corrosion of steel bars is likely or where sensitive electrical or magnetic equipment might be affected by a large amount of steel reinforcement. The development of the various fiber-reinforced polymer composites, or FRPs, has occurred over a number of decades and the materials continue

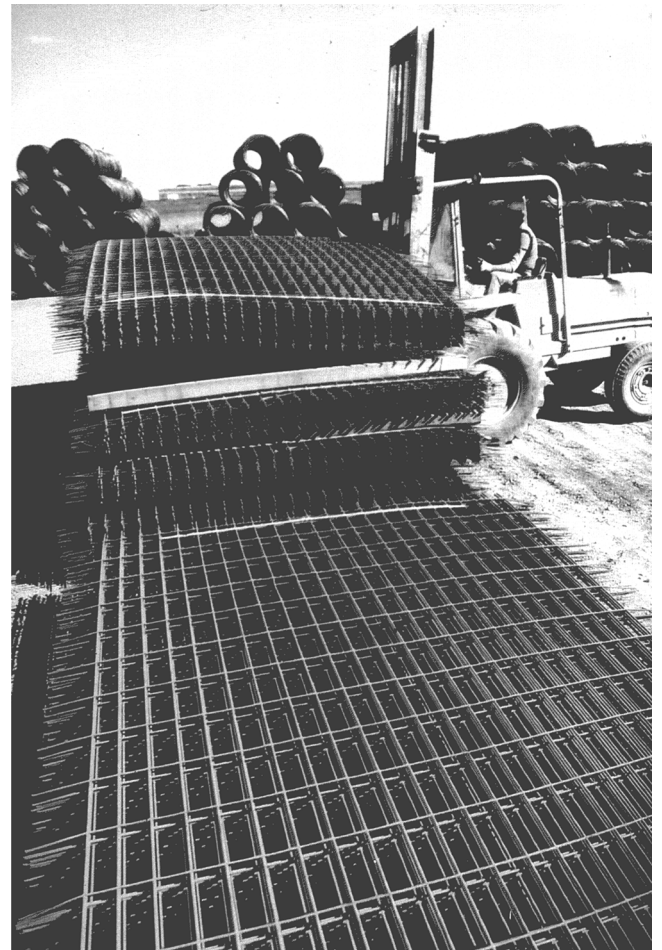

Fig. 3.1.3—Welded wire reinforcement sheets (courtesy of Wire Reinforcement Institute).

to evolve. (Originally, the "p" in FRP stood for "plastic," but "polymer" is now the preferred term to avoid confusion.) FRP materials are available in many forms, including bars, tapes, cables, grids, sheets, and plates.

FRP bars have several qualities that make them suitable as reinforcement for concrete: they thermally expand and contract at a rate very close to that of concrete, they do not rust, and they have a very high strength-weight ratio. In addition, FRP is nonmagnetic. The main FRP benefit for the construction industry is durability, as FRP composites do not rust. As such, bridges and paper and chemical plants have been the most common applications for FRP bars used to date. The electrical insulating properties are important in certain highly specialized applications, the best known being magnetic resonance imaging (MRI) equipment. Other benefits of FRP composites include light weight, high strength and high modulus, electromagnetic permeability, and impact resistance. Disadvantages of FRP bars include their brittle nature (they do not stretch as far as steel bars before breaking), their susceptibility to damage from ultraviolet light, and the fact that they cannot be field-bent.

3.2.1 FRP materials—FRP bars are most commonly made using glass, carbon, or aramid fibers. FRP materials are not as

fire-resistant as steel, and some are damaged by exposure to ultraviolet radiation (UV). Moisture can significantly reduce both the strength and stiffness of some FRP materials, although some resins are formulated to be moisture-resistant. Embedding the bar in concrete provides a level of protection from moisture and can alleviate many of the long-term durability concerns. In general, the resin in the FRP is more susceptible to damage than the fiber. Inorganic polymers can be substituted for organic polymers to provide better resistance to fire and UV. Carbon fibers are the most chemical-resistant of the various fibers used.

Bars are the most common form of FRP composites. Bars may contain only one type of fiber—glass, carbon, or aramid—or may be some combination of these fibers. Individual bar diameters vary from approximately 3 mm (1/8 in.) up to about 25 mm (1 in.).

In FRP composites, resins make up between 25 and 50% by weight of the bar. Resins hold the fibers together (in bars) and do not have the same physical properties as the fibers, or support loads as well as the fibers.

In general, the FRPs are about 1/4 the weight of steel. This can be beneficial for shipping costs and for ease of placing reinforcement. Glass FRP bars have about the same linear coefficient of expansion as concrete. Carbon FRP bars are unaffected by temperature, and aramid FRP bars shrink slightly rather than expand with temperature increases.

Many projects that use FRP bars are instrumented with monitoring devices in order to provide feedback on the performance of the structure. This information can be used to maintain structural safety and may provide long-term data for research projects. Because FRPs are made of many different materials by various manufacturers, their properties are more variable than steel. Steel follows a linear stress-strain curve until yield, then maintains a constant stress to failure, indicating ductile behavior. Unlike steel, FRPs are not ductile, and failure will be brittle once the ultimate tensile strength is reached. It is therefore important to keep the (sustained) loads below the ultimate strength by an adequate margin for safety.

FRP bars are designed to be used in tension only, because their compressive and shear strengths are low. However, the low shear strength is beneficial in some cases. For instance, FRPs used for temporary rock bolts in tunneling projects are cut much more easily than steel.

3.3—Fiber reinforcement

Fiber-reinforced concrete (FRC) is concrete with the addition of discrete reinforcing fibers made of steel, glass, synthetic (nylon, polyester, and polypropylene), and natural fiber materials. At appropriate dosages, the addition of fibers may provide increased resistance to plastic and drying shrinkage cracking, reduced crack widths, and enhanced energy absorption and impact resistance. The major benefit derived from the use of FRC is improved concrete durability.

Common lengths of discrete fibers range from 10 mm (3/8 in.) to a maximum of 75 mm (3 in.). They are normally added to the concrete during the batching operation but alternately can be added at the job site. It is important that sufficient mixing time be provided after fibers are added to a mixture. (A

minimum of 4 minutes may be required with a transit mixing drum spinning at mixing speed. In precast and central mixing plants, mixing efficiency is much higher and mixing time is reduced to as little as 90 seconds.)

Synthetic fibers can be delivered to the mixing system in preweighed, degradable bags that break down during the mixing cycle. Steel fibers are introduced to the rotating mixer via conveyor belt, either at the same time as the coarse aggregate, or on their own after all the conventional ingredients have been added.

Placement and finishing operations for FRC are comparable to those used for concrete without fibers.

3.3.1 Applications—The major applications of FRC are slab-on-grade construction, precast concrete, and shotcrete. Some examples of slab-on-grade construction are airport runways, residential, commercial, and industrial floor slabs, and hydraulic structures. There are a number of precast applications such as septic tanks and bumper blocks. Fiber-reinforced shotcrete is used for rock slope stabilization, tunnel liners, hydraulic structures, and maintenance of existing concrete. Fibers are also used in conjunction with steel reinforcing bar. FRC is also used in repair applications, such as repair of bridge decks, piers, and parapets.

3.3.2 Steel fibers—Steel fiber-reinforced concrete (SFRC) utilizes steel fibers meeting one of the following four general types listed in ASTM A 820:

- Type I: Cold-drawn wire
- Type II: Cut sheet
- Type III: Melt-extracted
- Type IV: Other fibers

The steel fibers are either produced from carbon steel or stainless steel. Carbon steel fibers are most common. Stainless steel fibers are used primarily in refractory applications.

The configuration of the steel fibers is very important in terms of mechanical bond with the concrete. Deformed steel fibers have a better mechanical bond than straight steel fibers of similar size. Likewise, for fibers of the same diameter, longer fibers provide higher pullout resistance than shorter ones.

3.3.2.1 Dosage—The typical dosage range for steel fibers is 12 to 71 kg/m³ of concrete (20 to 120 lb/yd³).

Dosages below 30 kg/m³ (50 lb/yd³) provide secondary reinforcement. Higher dosages can, depending on the type and length of steel fibers used, increase to varying degrees the flexural strength, fatigue strength, toughness, shear strength, impact resistance, and ductility over that of unreinforced concrete. The ability of SFRC to redistribute moments after microcracking in slabs-on-grade potentially allows for reduction in the slab thickness. For more information, see ACI Committee Reports 302.1R, Guide for Concrete Floor and Slab Construction; 330R, Guide for Design and Construction of Concrete Parking Lots; 360R, Design of Slabs on Grade; 506.1R, Fiber Reinforced Shotcrete); 544.1, State of the Art Report on Fiber Reinforced Concrete; 544.2, Measurement of Properties of Fiber Reinforced Concrete; 544.3, Guide for Specifying, Proportioning, Mixing, Placing, and Finishing Steel Fiber Reinforced Concrete; and 544.4, Design Considerations for Steel Fiber Reinforced Concrete.

Steel fibers should be added to the concrete batch mixer at a uniform rate to prevent segregation or balling during mixing.

3.3.3 Synthetic fibers—A variety of fiber materials other than steel, glass, or natural fibers (such as wood or other plant fibers) have been developed for use in FRC. These fibers are categorized as synthetic fibers. Concrete made with synthetic fibers is referred to as synthetic fiber-reinforced concrete (SNFRC). Synthetic fibers (Fig. 3.3.3) are man-made fibers resulting from research and development in the petrochemical and textile industries. Currently, nylon, polyester, and polypropylene fibers are the most common commercially available fibers for use in SNFRC.

Polypropylene is available as a fibrillated tape that looks like a hair net or fishing net when opened. During concrete mixing, the original bundles break down into mini-bundles, where three or four main fibrils are attached by cross fibrils. This mini-bundle provides excellent bond with the mortar infiltrating the net. Polypropylene and nylon are both available as a monofilament, which has a cylindrical cross-section of various diameters. The standard dosage range is 0.6 to 1.0 kg/m³ (1.0 to 1.6 lb/yd³) or roughly 0.1% by volume. At this dosage, synthetic fibers are used to modify plastic shrinkage and plastic settlement properties of concrete. Less bleed water is the visually observable result of reduced plastic settlement. Uses include slabs-on-grade, precast concrete, and wet-method shotcrete.

Cast-in-place concrete will accommodate up to 0.5% by volume with mixture proportion modifications required when the fiber volume is above 0.3%. Wet shotcrete mixtures with up to 0.75% by volume can be used to enhance toughness/residual strength. The use of 0.2% (1.8 kg/m³ [3 lb/yd³]) of synthetic fiber in ultra-thin white-topping (a concrete replacement for hot-mixed asphalt as the wearing surface) has become a standard based on proven performance.

Adding more than 0.3% by volume of synthetic fibers requires modification of the concrete mixture proportions to accommodate the increased surface area of the fiber. Increasing the sand content while decreasing the coarse aggregate content is required to have a workable mixture. If water is added to the mixture, the quantity of cement may need to be increased to maintain the required compressive strength. A high-range water-reducing admixture (also known as a superplasticizer), rather than additional water, is used to adjust for loss of slump.

3.4—Materials for repair and strengthening of structural concrete members

Strengthening a structural concrete member after it is built usually involves removing and replacing concrete, attaching additional material to the member, or wrapping the member in another material. Strengthening accomplished by adding or replacing concrete is beyond the scope of this document. Strengthening by adding reinforcing bar or prestressing reinforcement (external to the member) uses materials covered elsewhere in this document.

3.4.1 External steel reinforcement—Structural steel plates or structural shapes can be used to externally reinforce concrete members. Depending on the application, plates,

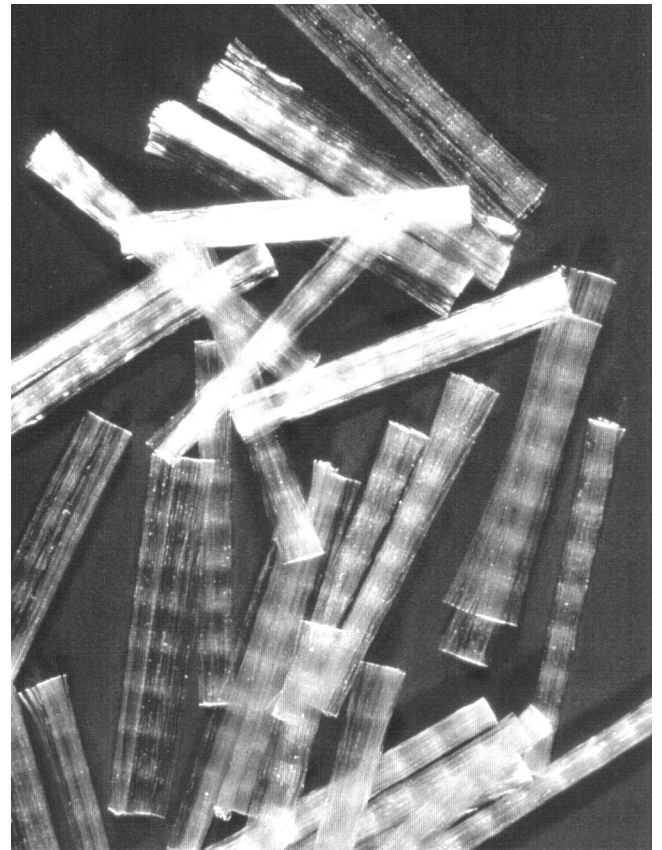

Fig. 3.3.3—Typical fibrillated, synthetic, polypropylene fibers magnified many times (courtesy of Fibermesh Inc.).

structural shapes or prestressed steel straps can be attached to the member with bolts, epoxy, or both. Care must be exercised when using epoxy to prevent damage by exposure to ultraviolet light. Bolts can either go through the member or be secured in drilled holes with epoxy. For beam repairs, plates or channels are frequently attached to the bottom or both sides of the beam, or where all sides of the beam are accessible, the beam can be wrapped and prestressed with steel straps. Both the bending and shear strength of the beam can be increased by these methods. For columns, plates are commonly placed on all sides to form a continuous shell or jacket, increasing the ductility and/or shear strength of the column. This is particularly common when retrofitting columns to resist earthquake forces. These jackets can be square, rectangular, round, or oval shaped. When the shape of the jacket is not identical to the shape of the column, the annular space—the space between the steel shell and the concrete column—is usually filled with a cementitious grout. Cracked walls can be repaired by attaching steel plates or a series of channels to the face of the wall, or by “stapling” the crack with a series of C-shaped reinforcing bars doweled into the face of the wall on either side of the crack.

3.4.2 FRP plates, sheets, and jackets—Several types of glass, carbon, or aramid fiber-reinforced polymer (FRP) composites are used to strengthen concrete members. FRP sheets come in two forms, precured laminates (that is, rigid plates) that can only be applied to flat surfaces, and thin sheets that can either be attached to flat surfaces or wrapped around



Fig. 3.4.2—Installation of FRP sheets on a reinforced concrete beam (courtesy of Hexcel Fyfe Co.).

columns or beams (Fig. 3.4.2) by in-place impregnation with resin (manual lay-up). In either case, they are typically attached to the concrete with epoxy. Rigid plates are most commonly attached to the bottom of beams to increase flexural capacity, or to reduce deflections. Flexible sheets can be used to strengthen flexural members. They are also used for shear strengthening or confinement of round or rectangular members, particularly columns and beams. In confinement applications, the sheets are usually continuously wrapped around the member to form a jacket that increases the strength, ductility, and shear capacity. Sheets can also be applied to walls and floor slabs to increase bending strength and in-plane shear capacity, as well as to reduce deflections. Additional information can be found in ACI 440R, “State-of-the-Art Report on Fiber Reinforced Plastic (FRP) Reinforcement for Concrete Structures.”

CHAPTER 4—PRESTRESSING MATERIALS

High-strength steel is the most commonly used material for prestressing concrete; however, other materials such as fiber-reinforced polymers (FRP) are also used. For additional information, ACI 440R, State-of-the-Art Report on Fiber Reinforced Plastic (FRP) Reinforcement for Concrete Structures, is recommended.

4.1—Steel

Prestressing steel is available in the form of strand, wire, and bar used singly or in bundles, and normally conforms to ASTM standard specifications.

4.1.1 Seven-wire strand—The most commonly used prestressing steel is seven-wire strand (Fig. 4.1.1). Seven-wire strand comes in two grades, Grade 1725 (250) and Grade 1860 (270) with minimum ultimate tensile strengths (MUTS)—breaking strengths—of 1725 MPa (250,000 psi) and 1860 MPa (270,000 psi), respectively. In addition, seven-wire strands are classified as stress-relieved or low-relaxation (also known as Lowlax). Low-relaxation strand has less of a tendency to *relax* or lose tension after it has been stretched and is considered the standard type. Stress-relieved strand is furnished only if specifically ordered.

Grade 1725 (250) strand conforming to ASTM A 416M/A 416 is manufactured in six sizes, designated by their nominal diameter in millimeters and listed in Table 4.1.1. Grade 1860 (270) strand is manufactured in four sizes similarly designated by their nominal diameter in millimeters and listed in Table 4.1.1. Tendons made from seven-wire strands can have as few as one or more than 50 strands per tendon. Tendons made from seven-wire strand are tensioned using hydraulic jacks and then held by steel wedges that fit into steel anchorages.

4.1.2 Wire—Prestressing wire conforming to ASTM A 421M/A 421 is manufactured in Grades 1620 (235) and 1655 (240) in type BA (used for applications with button anchors), and in Grades 1620 (235), 1655 (240) and 1725 (250) in type WA (used for applications with wedge anchors). Like prestressing strand, prestressing wire is classified as stress-relieved or low-relaxation. Prestressing wire is manufactured in four sizes designated by its nominal diameter. Available sizes of prestressing wire are listed in Table 4.1.2. Like prestressing strand, prestressing wire can be used individually or in multi-wire tendons.

4.1.3 Bars—Prestressing bars (Fig. 4.1.3) conforming to ASTM A 722M/A 722 are manufactured in only one grade, Grade 1035 (150), with a minimum ultimate tensile (breaking) strength of 1035 MPa (150,000 psi). They are manufactured in both plain and deformed bars referred to as Type I and Type II, respectively. Plain bars, which often have threads machined onto them, are manufactured in six sizes designated by their nominal diameter in millimeters or inches, as listed in Table 4.1.3. The deformations on deformed bars are usually arranged in a thread-like pattern. Deformed bars are manufactured in several sizes designated by their nominal diameter in millimeters or inches and are also listed in Table 4.1.3. Prestressing bars are usually tensioned using hydraulic jacks and anchored by threaded nuts and anchor plates.

4.2—FRP

Bars are the basic components from which the prestressing reinforcement is usually manufactured. For prestressing applications, single bars or combinations of bars are the most common form, and are referred to as tendons. Tendons can be made by braiding small-diameter bars, by twisting bars or strands, or by bundling strands. Flat strips, tapes, or rods can also be bundled together (usually 3, 8, or 9) to make tendons,

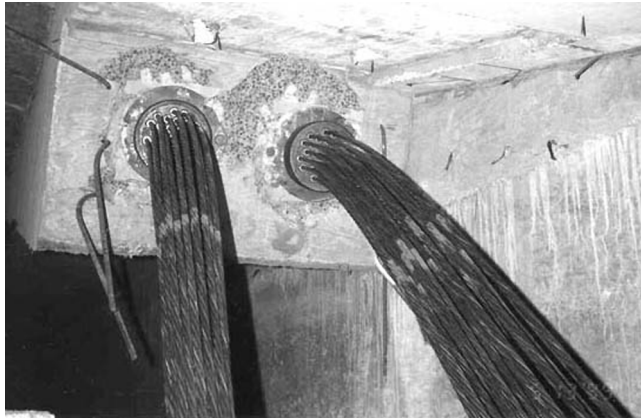

Fig. 4.1.1—Typical seven-wire prestressing strand (courtesy of HDR Engineering).

Table 4.1.1—ASTM standard seven-wire prestressing strand

Type	Nominal diameter	
	mm	in.
Seven-wire strand, Grade 1725 (250)	6.35	1/4 (0.250)
	7.94	5/16 (0.313)
	9.53	3/8 (0.375)
	11.11	7/16 (0.438)
	12.70	1/2 (0.500)
Seven-wire strand, Grade 1860 (270)	15.24	6/10 (0.600)
	9.53	3/8 (0.375)
	11.11	7/16 (0.438)
	12.70	1/2 (0.500)
	15.24	6/10 (0.600)

Table 4.1.2—ASTM standard prestressing wire sizes

Type	Nominal diameter	
	mm	in.
BA or WA	4.88	0.192
	4.98	0.196
	6.35	0.250
	7.01	0.276

while cables (ropes) are usually 3, 7, or 19 bars twisted together. Bars as large as 45 mm (1-3/4 in.) nominal diameter have been fabricated by combining 61 individual strands. FRP prestressing is used in much the same manner as steel. If tendons are placed in ducts, the ducts may be ungrouted or they may be filled with grout to provide added protection to the tendon. Sheet materials are not used for prestressing.

FRP prestressing can be either external or internal. External prestressing is usually unbonded, but can be bonded. Internal prestressing is usually bonded. Unbonded FRP tendons often do not contain a resin matrix holding the individual bars together. Instead, the tendons are simply a grouping of bars. Multistrand tendons made without resin holding the individual bars together are more flexible than bar groupings bonded

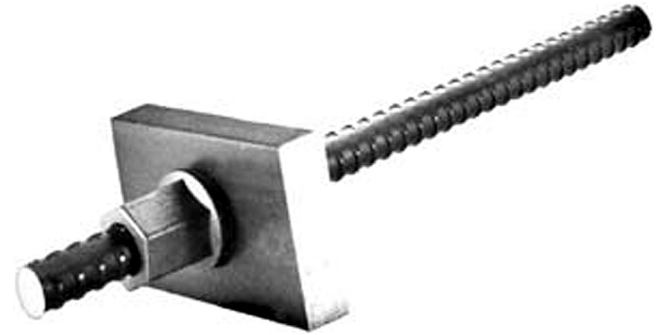

Fig. 4.1.3—High strength threaded bar and anchor plate for prestressing (courtesy of DYWIDAG Systems International).

Table 4.1.3—ASTM standard prestressing bars

	Nominal diameter	
	mm	in.
Type I Bar, plain	19	3/4
	22	5/8
	25	1
	29	1-1/8
	32	1-1/4
	35	1-3/8
Type II bar, deformed	15	5/8
	20	3/4
	26	1
	32	1-1/4
	36	1-3/8
	40	1-3/4
	65	2-1/2

with resin. Thus, tendons that contain a minimal amount of resin are stronger than an equivalent-diameter bar made from the same type of fiber. Tendons must be anchored securely to the concrete, either by mechanical fasteners or through the use of epoxy.

4.2.1 Strength—Because FRPs are made of many different materials by various manufacturers, their properties are more variable than steel. The ultimate strength of FRP tendons is comparable to that of a steel prestressing strand. The tensile strength of steel tendons generally ranges between about 1400 and 1900 MPa (200 to 270 ksi); for glass fiber tendons, the range is from about 1400 to 1700 MPa (200 to 250 ksi); for carbon fiber tendons, which are among the strongest of the fibers, the range is from 1650 to 2400 MPa (240 to 350 ksi); and for aramid fiber tendons, the range is from 1200 to almost 2100 MPa (170 to 300 ksi). FRP carbon tendons are more commonly used for prestressing than other fiber types because of their high strength and high modulus.

4.2.2 Applied loads—Tendons are subjected to short-term loads during construction (prestressing) and to long-term (service) loads. Prestressing loads are usually larger than service loads. Tendons are subjected to anywhere from 30 to 80% of the rated tensile capacity (MUTS) of the tendon during prestressing operations. The sustained tensile force is limited to 60% of the minimum ultimate tensile strength because of a

phenomenon known as creep rupture that affects all materials, including FRP tendons and steel prestressing strands. In creep rupture, tensile members subjected to sustained loads fail suddenly after a certain period of time. Creep rupture is not a concern for most FRP reinforced concrete structures, because the FRP service stress is usually below 60%. However, it is important for prestressing applications where higher FRP stresses are more common. Another concern with FRP tension stress at or above 60% of MUTS is fatigue failure. Fatigue testing performed on carbon FRP tendons indicates that if the mean stress is 60% of the ultimate strength or less, fatigue failure is rare.

CHAPTER 5—CORROSION-RESISTANT REINFORCEMENT

The high pH and relatively low permeability of concrete provides passive corrosion protection for steel. However, this protection is not sufficient in certain wetting and drying environments or in environments that chemically promote the corrosion of steel reinforcement. Because steel is susceptible to rusting when exposed to air and water, reinforcing steel in concrete, which is likely to be frequently wet or exposed to corrosive chemicals such as deicing salt or seawater, often requires protection beyond that provided by the concrete. Several methods are commonly used to protect steel reinforcement from rusting. The most common of these methods is epoxy coating. Galvanized and stainless steel reinforcement, cathodic protection systems, and chemical and mineral corrosion protection systems are also used to protect steel reinforcement, but are less common than epoxy-coated reinforcement.

5.1—Epoxy coating

Steel reinforcing bars, wire and welded wire fabric, and steel prestressing strand can be manufactured with a fusion-bonded epoxy coating (Fig. 5.1) according to ASTM A 775M/A 775 or A 934M/A 934 for reinforcing bars, A 884M/A 884 for wire and welded wire fabric, and A 882M/A 882 for prestressing strand. The epoxy coating, which can be recognized by its color (usually green or purple), acts as a barrier preventing the steel from being exposed to air, water, and other oxidizing agents. The epoxy coating can be applied to reinforcing bars before (ASTM A 775M/A 775) or after (ASTM A 934M/A 934) bending and cutting the bars in the fabricating shop. If the epoxy coating is applied prior to fabrication, any damage to the epoxy coating that occurs during fabrication is repaired prior to shipping the bars to the construction site.

Epoxy-coated reinforcement is common in bridge decks, parking, and other transportation structures, and structures in or near salt water.

5.2—Galvanizing

Deformed steel bars and steel prestressing wire can also be coated with zinc in accordance with ASTM A 767M/A 767 in a process called galvanizing. The zinc coating, applied by dipping prepared reinforcing bars into a molten bath of zinc, provides both a barrier to corrosive attack and a sacrificial layer that, when damaged, forms a galvanic couple with the

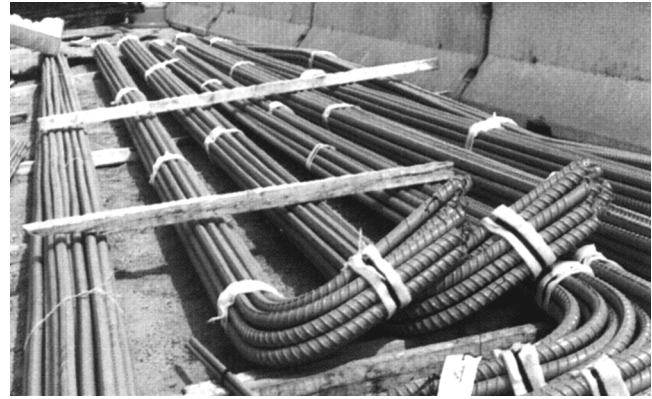

Fig. 5.1—Epoxy-coated reinforcing bar (courtesy of Concrete Reinforcing Steel Institute).

zinc as the anode. Galvanizing is usually applied after fabrication of the bars to prevent damage to the coating from bending and cutting.

5.3—Stainless steel

Deformed steel bars are also manufactured from stainless steel according to ASTM A 955M or with a stainless steel cladding. In addition to having enhanced corrosion resistance, stainless steel bars have controlled magnetic permeability.

ASTM Specification A 955M covers three grades of stainless steel bars—300, 420, and 520—having minimum yield strengths of 300, 420, and 520 MPa, respectively (40, 60, and 75 ksi). Sizes of stainless steel bars are the same as for standard carbon steel bars (see Section 3.1.1.2).

Another type of stainless steel reinforcement, stainless steel-clad bars, is emerging. The cladding is a barrier coating which, like epoxy-coating, prevents corrosive agents from coming in contact with the core of the bar.

5.4—Chemical and mineral corrosion protection systems

Chemical and mineral admixtures added to concrete during batching can be used to protect embedded reinforcement by delaying the onset of corrosion. For more information, see ACI Education Bulletin E4 and Committee Reports 212.3R, Chemical Admixtures for Concrete; 232.1R, Use of Natural Pozzolans in Concrete; 232.2R, Use of Fly Ash in Concrete; 233R, Ground Granulated Blast-Furnace Slag as a Cementitious Constituent in Concrete; and 234R, Guide for the Use of Silica Fume in Concrete.

CHAPTER 6—STORAGE AND HANDLING

6.1—Uncoated steel reinforcement

Storage conditions should not cause excessive rusting of the reinforcement or the adherence of dust or soil. On the job site, reinforcement is usually stored on heavy timbers to keep it out of mud and water. Before reinforcing steel is placed, it should be free of coatings that reduce the bond of steel to concrete, particularly oil, dirt, loose mill scale, and loose rust. Coatings likely to be found on parts of the reinforcement are paint, oil, grease, dried mud, and weak dried mortar that has been splashed on the bars. Dried loose mortar should be brushed

from the bars; mortar that is difficult to remove is harmless and can remain. Oil and grease should be removed with a degreaser. Special care must be taken when applying a release agent to wood or steel form work to avoid contamination of the reinforcing bar with the release agent. A thin, adherent film of rust or mill scale is not objectionable and may even improve the bond between the bar and surrounding concrete, but loose rust or mill scale should be removed.

6.2—Epoxy-coated steel reinforcement

All of the precautions noted in Section 6.1 for uncoated reinforcing bar also apply to bars with epoxy coating. In addition, epoxy-coated bars should be stored and handled so that the coating is not damaged prior to concrete placement. Epoxy-coated reinforcement should be handled only with nonmetallic equipment such as nylon slings or padded wire rope. Epoxy-coated bars should never be dragged along the ground or off a truck. Long bundles should be lifted with power equipment at multiple pick-up points or with a spreader bar and stored on heavy timber cribbing spaced closely enough to prevent both sagging and bar-to-bar abrasion that might damage the epoxy coating.

Flame cutting should not be permitted. Instead of flame cutting, bars should be saw-cut or sheared to minimize damage to the coating.

Epoxy-coated bars should always be placed on plastic coated or epoxy-coated wire bar support. Tie wire should be coated tie wire. Bars should not be dragged over one another to get them into position; they should be carried to their final position and placed carefully. Walking on bars should be minimized to prevent damaging the coating.

During concrete placement, rubber coated vibrators should be used to prevent damage to the epoxy coating.

Even when all of the proper precautions are taken, damage to the epoxy coating can occur in the course of storage, handling, field-cutting and placing coated reinforcement. When damage does occur, it should be immediately reported to the inspector so that the damaged coating can be repaired with an approved epoxy repair material.

6.3—FRP

As with steel reinforcement, nonferrous reinforcement, such as FRP, should be stored off the ground on heavy timber cribbing and should be kept free of dirt, oil, loose concrete, and any other contaminant that might interfere with the bond between the reinforcement and concrete. In addition, FRP reinforcement is susceptible to chemical attack from oil, grease, or alkaline substances that can reduce its strength and should therefore have any contaminant removed promptly. Similarly, extended exposure to sunlight and its ultraviolet rays should be avoided to prevent degradation of the mechanical properties of FRP reinforcement.

6.4—Fiber reinforcement

Ferrous fibers should be stored and transported in a manner that protects them from moisture, oil, grease, or other contaminants that would cause them to rust or impair their bond with concrete. Care of nonferrous fibers is similar, but they should

also be protected against prolonged exposure to ultraviolet rays from sunlight.

CHAPTER 7—REFERENCES

Referenced standards and reports

The following list shows the ACI and ASTM documents cited in this bulletin with their serial designations.

American Concrete Institute

116R	Cement and Concrete Terminology
212.3R	Chemical Admixtures for Concrete
232.1R	Use of Natural Pozzolans in Concrete
233R	Ground-Granulated Blast-Furnace Slag as a Cementitious Constituent in Concrete
234R	Guide to the Use of Silica Fume in Concrete
301	Specifications for Structural Concrete
302.1R	Guide for Concrete Floor and Slab Construction
315	Details and Detailing of Concrete
318/318R	Building Code Requirements for Structural Concrete
330R	Guide for Design and Construction of Concrete Parking Lots
360R	Design of Slabs on Grade
440R	Report on Fiber Reinforced Plastic (FRP) Reinforcement for Concrete Structures
506.1R	Fiber-Reinforced Shotcrete
544.1R	Report on Fiber-Reinforced Concrete (FRP) Reinforcement for Concrete Structures
544.2R	Measurements of Properties of Fiber-Reinforced Concrete
544.3R	Guide to Specifying, Proportioning, Mixing, Placing, and Finishing Steel Fiber-Reinforced Concrete
544.4R	Design Considerations for Steel Fiber-Reinforced Concrete

ASTM

A 184/	Standard Specification for Fabricated Deformed Steel Bar Mats for Concrete Reinforcement
A 184M	
A 185	Standard Specification for Steel Welded Wire Fabric, Plain, for Concrete Reinforcement
A 416/	Standard Specification for Steel Strand, Uncoated Seven-Wire for Prestressed Concrete
A 416M	
A 421/	Standard Specification for Uncoated Stress-Relieved Steel Wire for Prestressed Concrete
A 421M	
A 497	Standard Specification for Steel Welded Wire Fabric, Deformed, for Concrete Reinforcement
A 615/	Standard Specification for Deformed and Plain Billet-Steel Bars for Concrete Reinforcement
A 615M	
A 706/	Standard Specification for Low-Alloy Steel Deformed and Plain Bars for Concrete Reinforcement
A 706M	
A 722/	Standard Specification for Uncoated High-Strength Steel Bar for Prestressing Concrete
A 722M	
A 767/	Standard Specification for Zinc-Coated (Galvanized) Steel Bars for Concrete Reinforcement
A 767M	

A 775/ Standard Specification for Epoxy-Coated
A 775M Reinforcing Steel Bars
A 820 Standard Specification for Steel Fibers for Fiber-
Reinforced Concrete
A 882/ Standard Specification for Epoxy-Coated Seven-
A 882M Wire Prestressing Steel Strand
A 884/ Standard Specification for Epoxy-Coated Steel
A 884M Wire and Welded Wire Fabric for Reinforcement
A 934/ Standard Specification for Epoxy-Coated Prefab-
A 934M ricated Steel Reinforcing Bars
A 955M Standard Specification for Deformed and Plain
Stainless Steel Bars For Concrete Reinforcement

A 996/ Standard Specification for Rail-Steel and Axle-
A 996M Steel Deformed Bars for Concrete Reinforcement

Other references

Placing Reinforcing Bars, 7th edition, Concrete Reinforcing Steel Institute, Chicago, 1996, 201 pp.

Manual of Standard Practice, 26th edition, Concrete Reinforcing Steel Institute, Chicago, 1996, 84 pp.

Reinforcement: Anchorages, and Splices, fourth edition, Concrete Reinforcing Steel Institute, Chicago, 1996, 37 pp.