

FORM FOUND DESIGN

“I like reinforced concrete because in it we find all the static, plastic, and structural characteristics of all other materials and, at the same time, it offers almost unlimited and not yet explored possibilities”.

-Pier Luigi Nervi





FABRIC FORMS

UCLA
2014



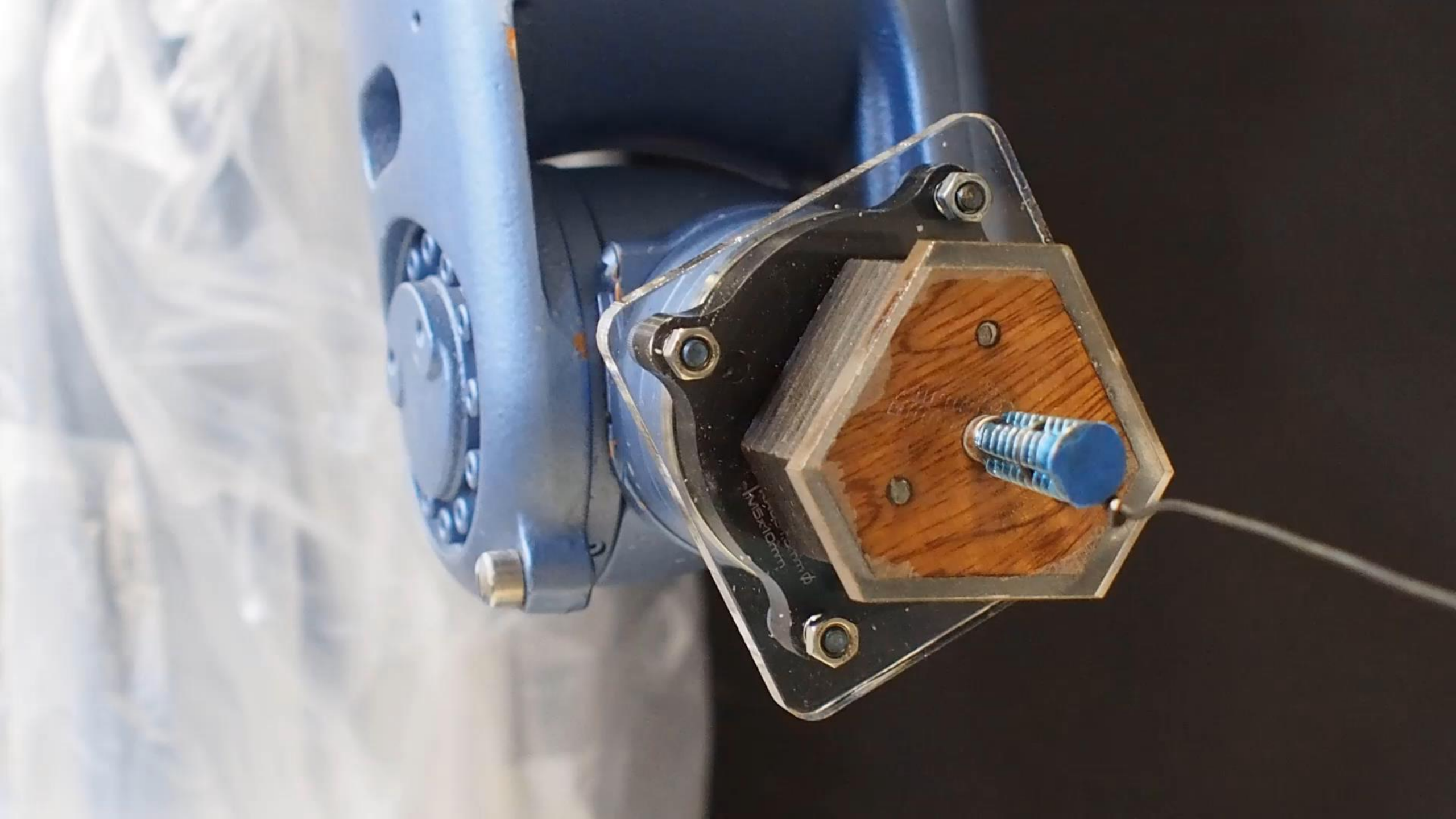



**MARS
PAVILION**

Palm Springs
2017

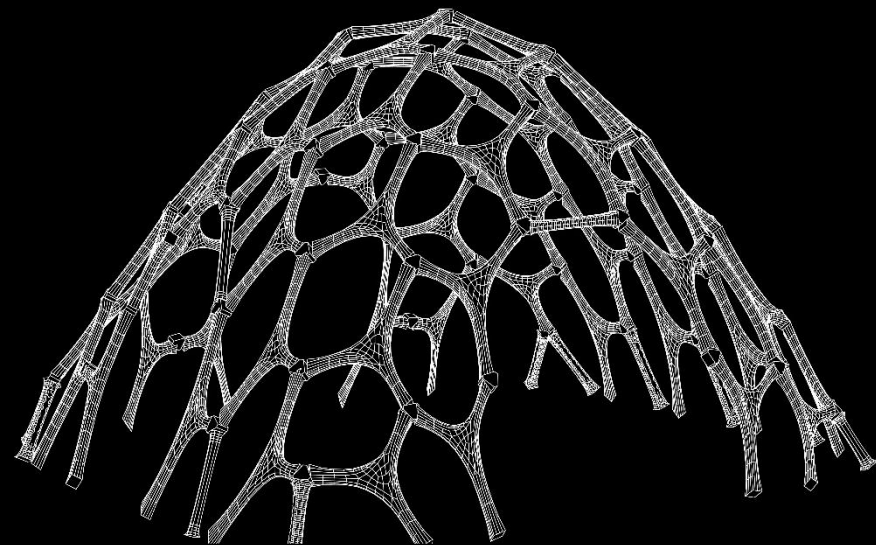
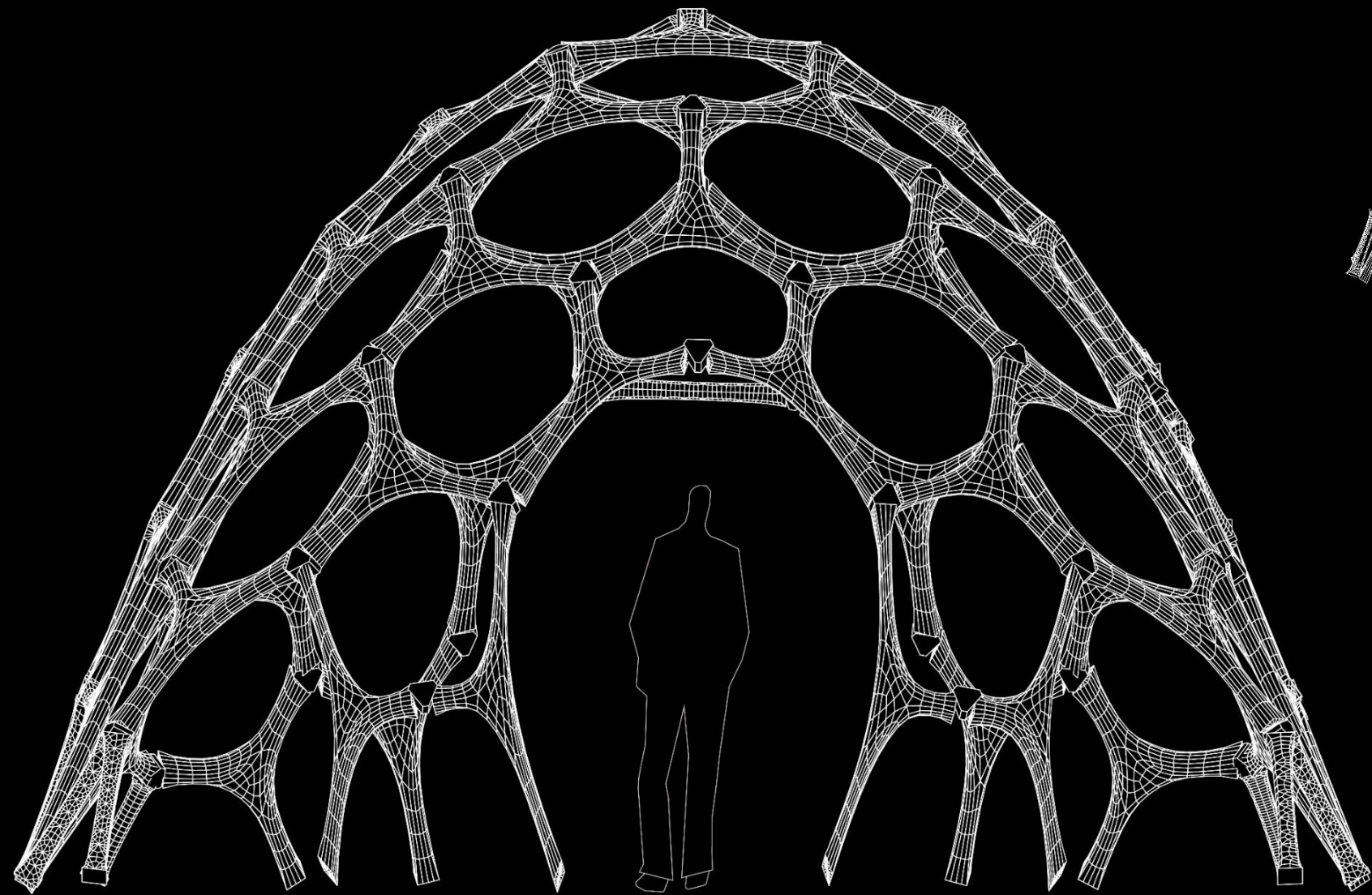

Architectural Design Model

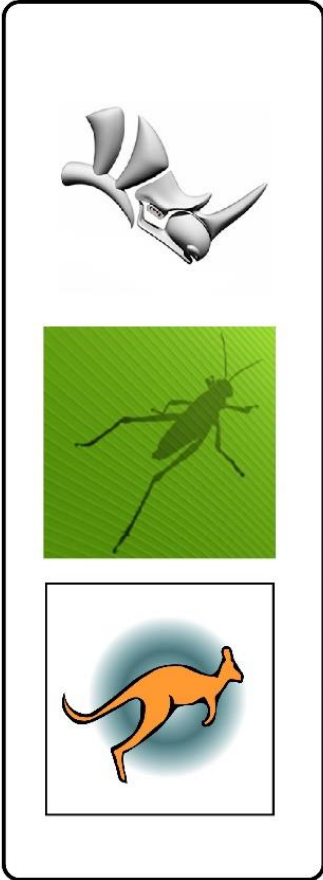

Engineering Analysis

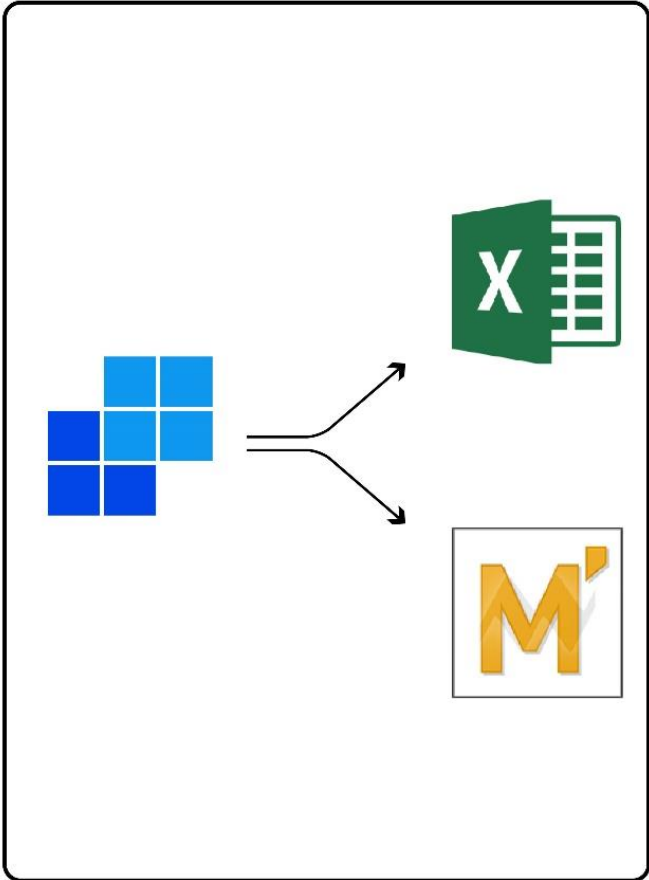

Architectural Production Model

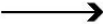

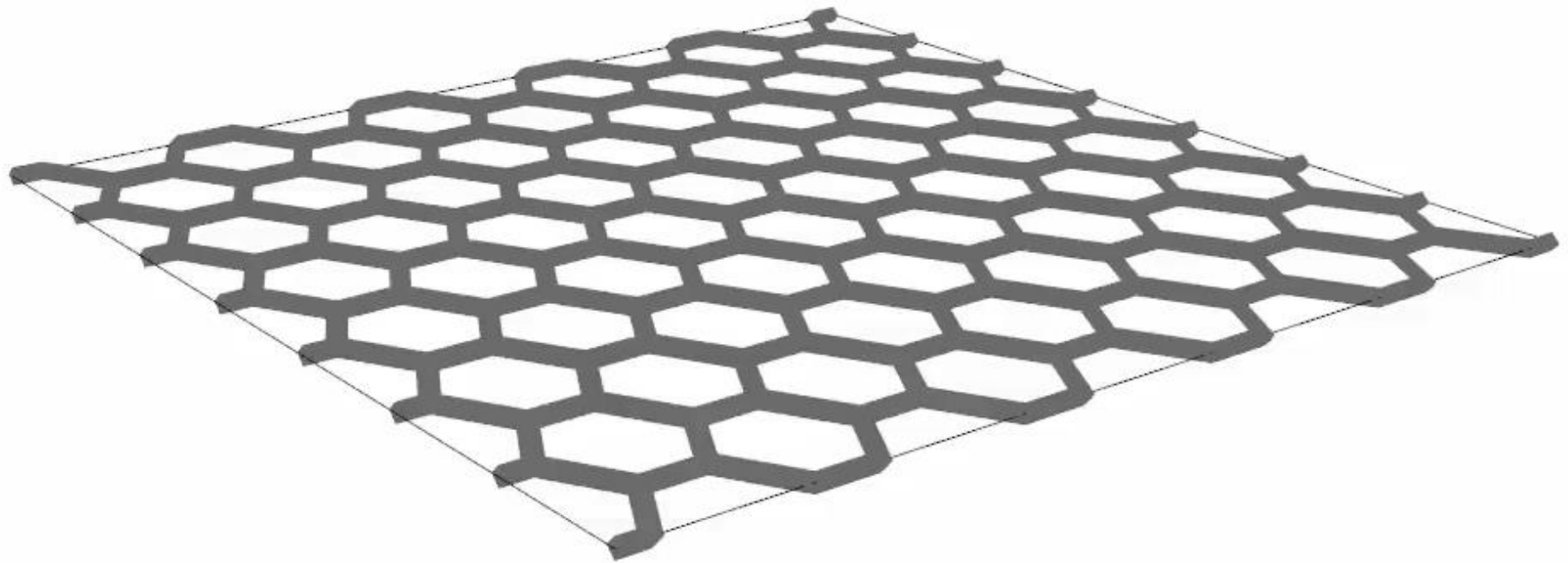

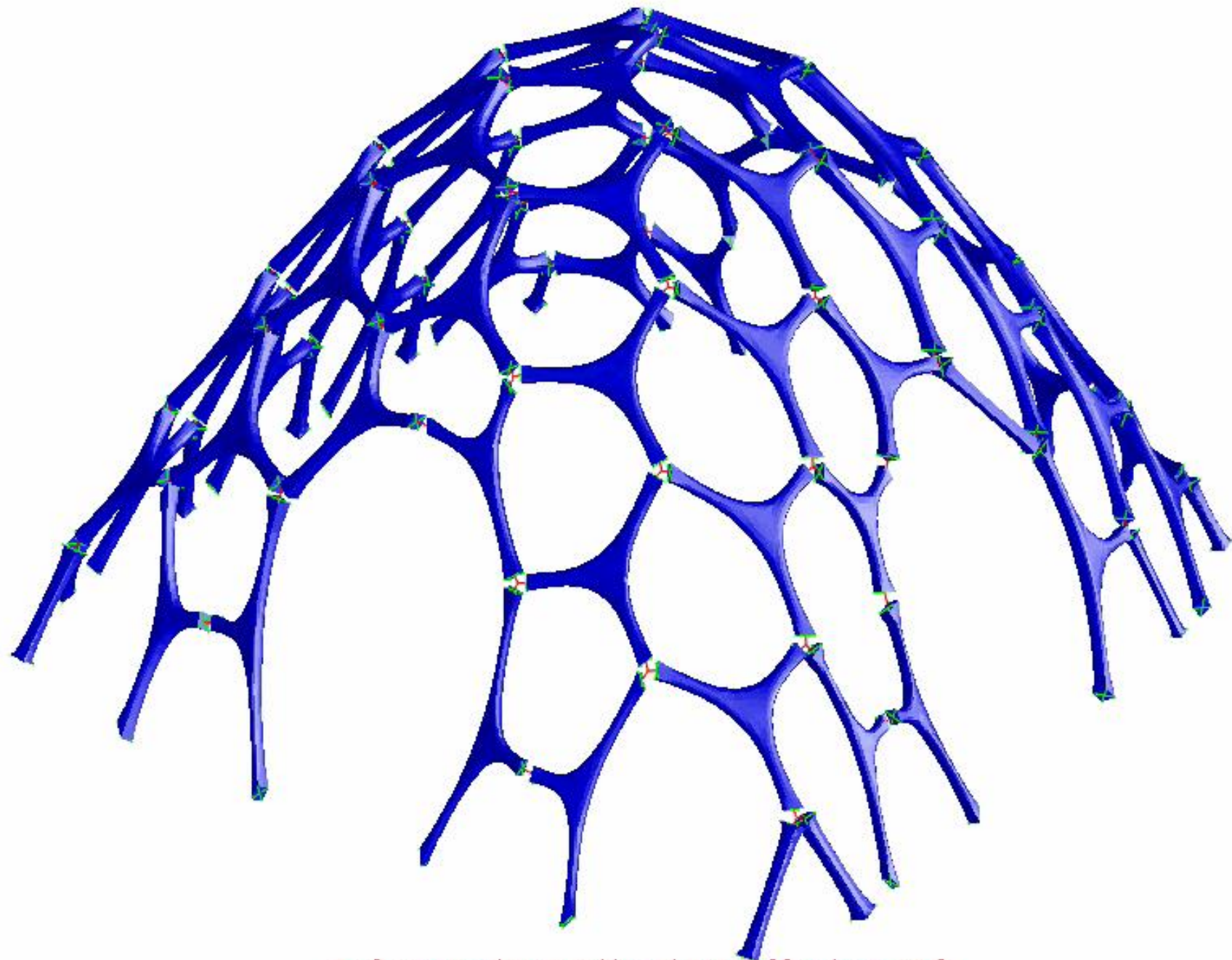

18: [Connection:(0.9 - 0.2Sds) Dead +2.0 EQy] [Combination 13]

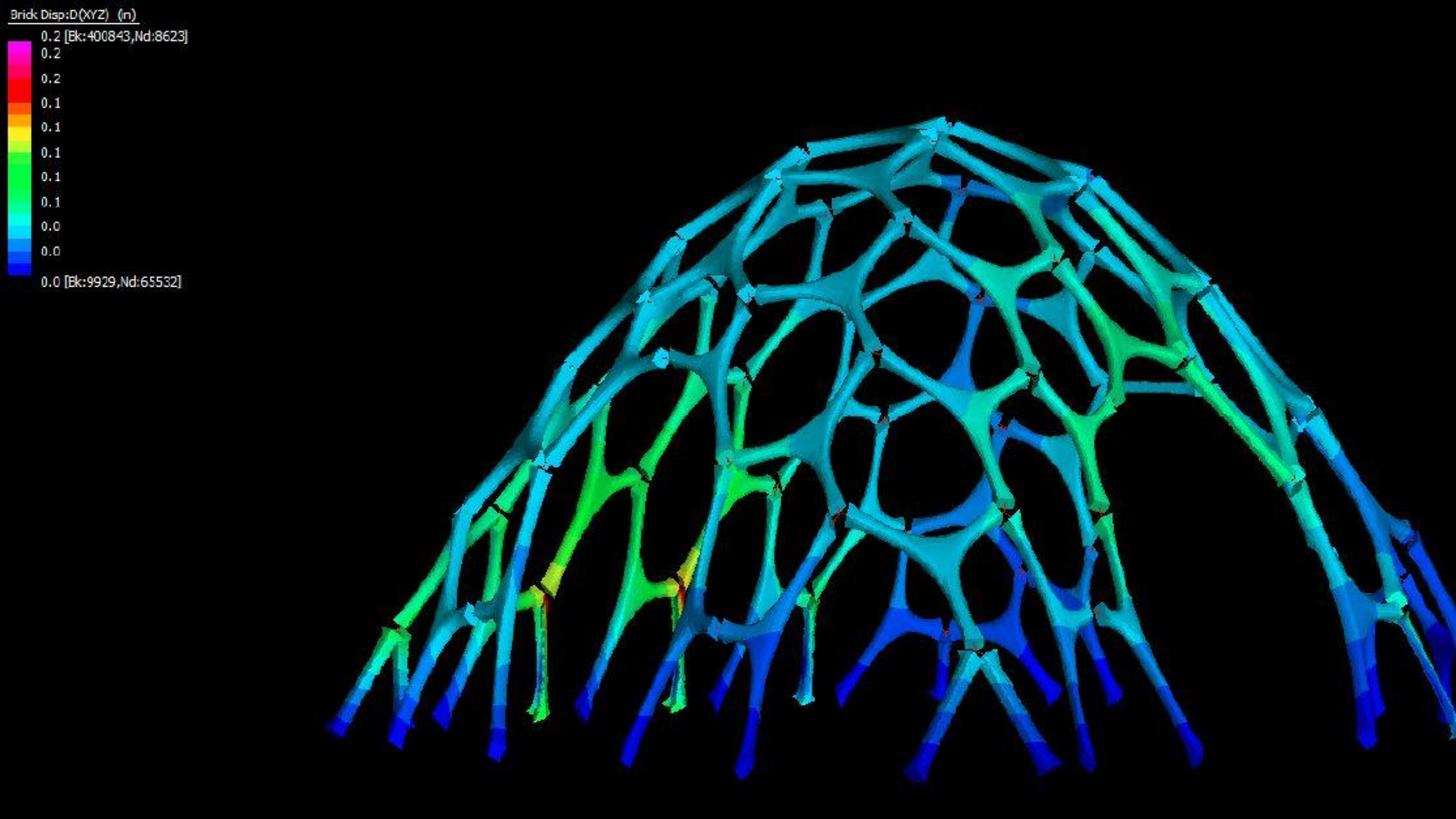

$$\frac{\sigma_{11}}{\Phi T n} < 100\%$$

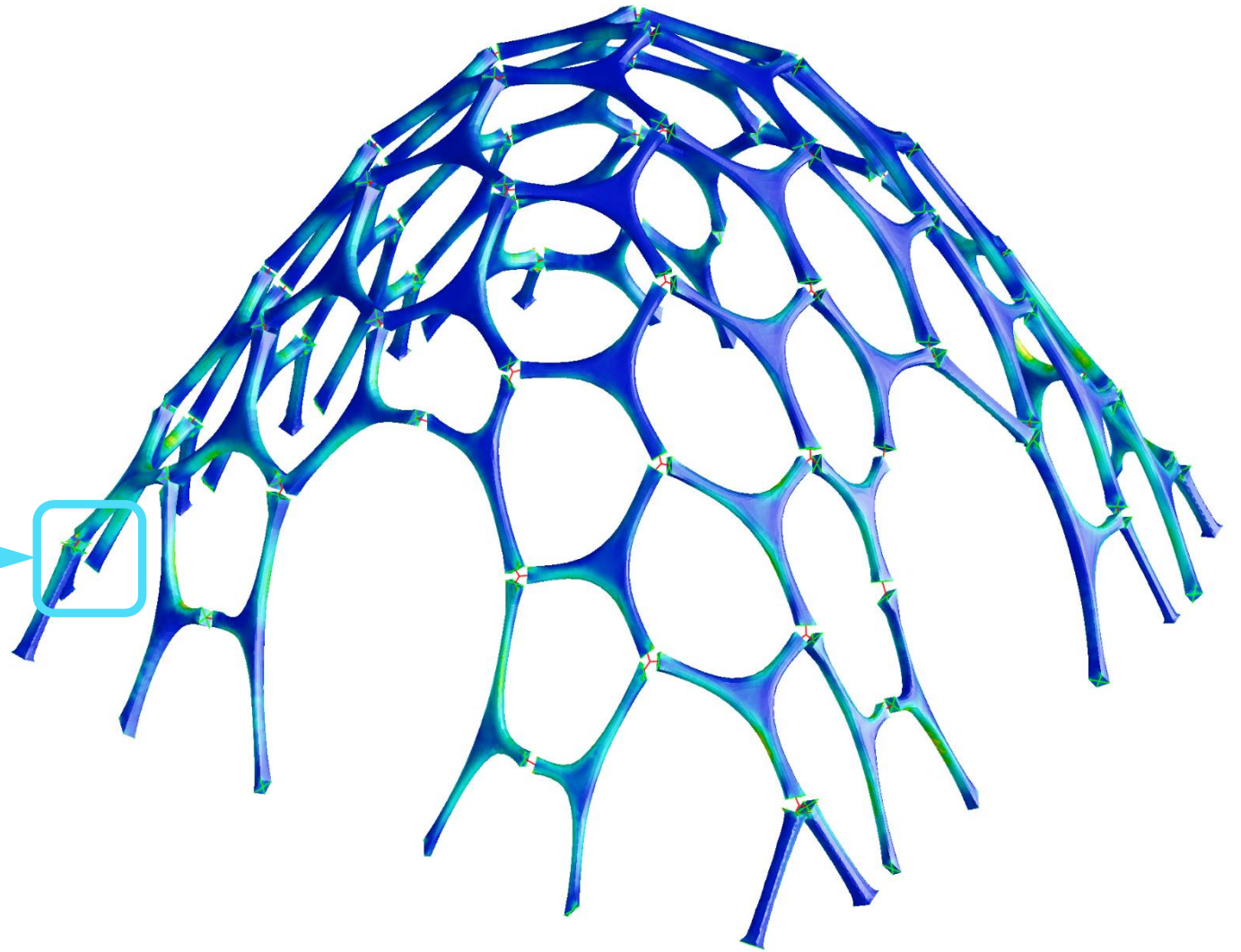
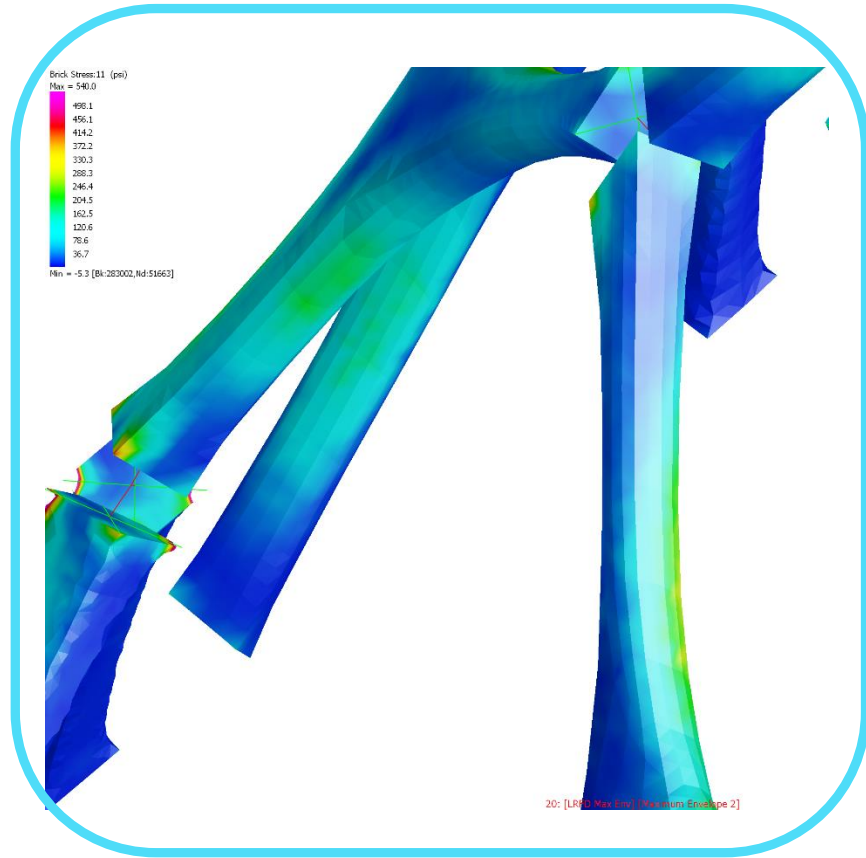

	Required Tensile Stress (psi)	$\phi T n$, Tensile Stress Capacity (psi)	Demand/Capacity Ratio	Required Compressive Stress (psi)	$\phi P n$, Compressive Stress Capacity (psi)	Demand/ Capacity Ratio
General Member (Global)	450 psi	540 psi	83%	1000 psi	8100 psi	12%

Brick Stress:11 (psi)

Max = 540.0

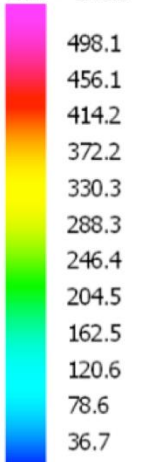

Min = -5.3 [Bk:283002,Nd:51663]

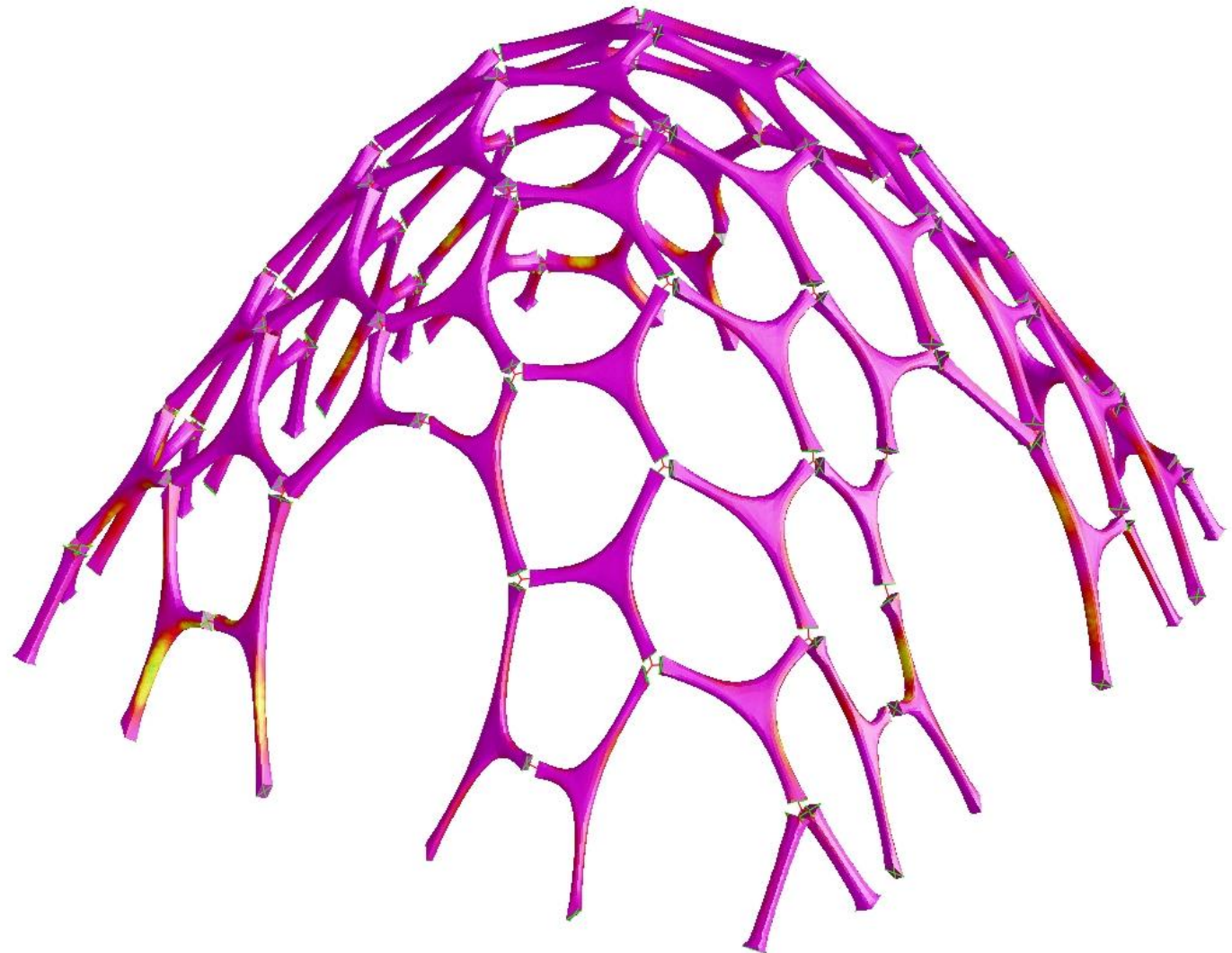

$$\frac{\sigma_{33}}{\Phi P_n} < 100\%$$

	Required Tensile Stress (psi)	ϕT_n , Tensile Stress Capacity (psi)	Demand/Capacity Ratio	Required Compressive Stress (psi)	ϕP_n , Compressive Stress Capacity (psi)	Demand/ Capacity Ratio
General Member (Global)	450 psi	540 psi	83%	1000 psi	8100 psi	12%



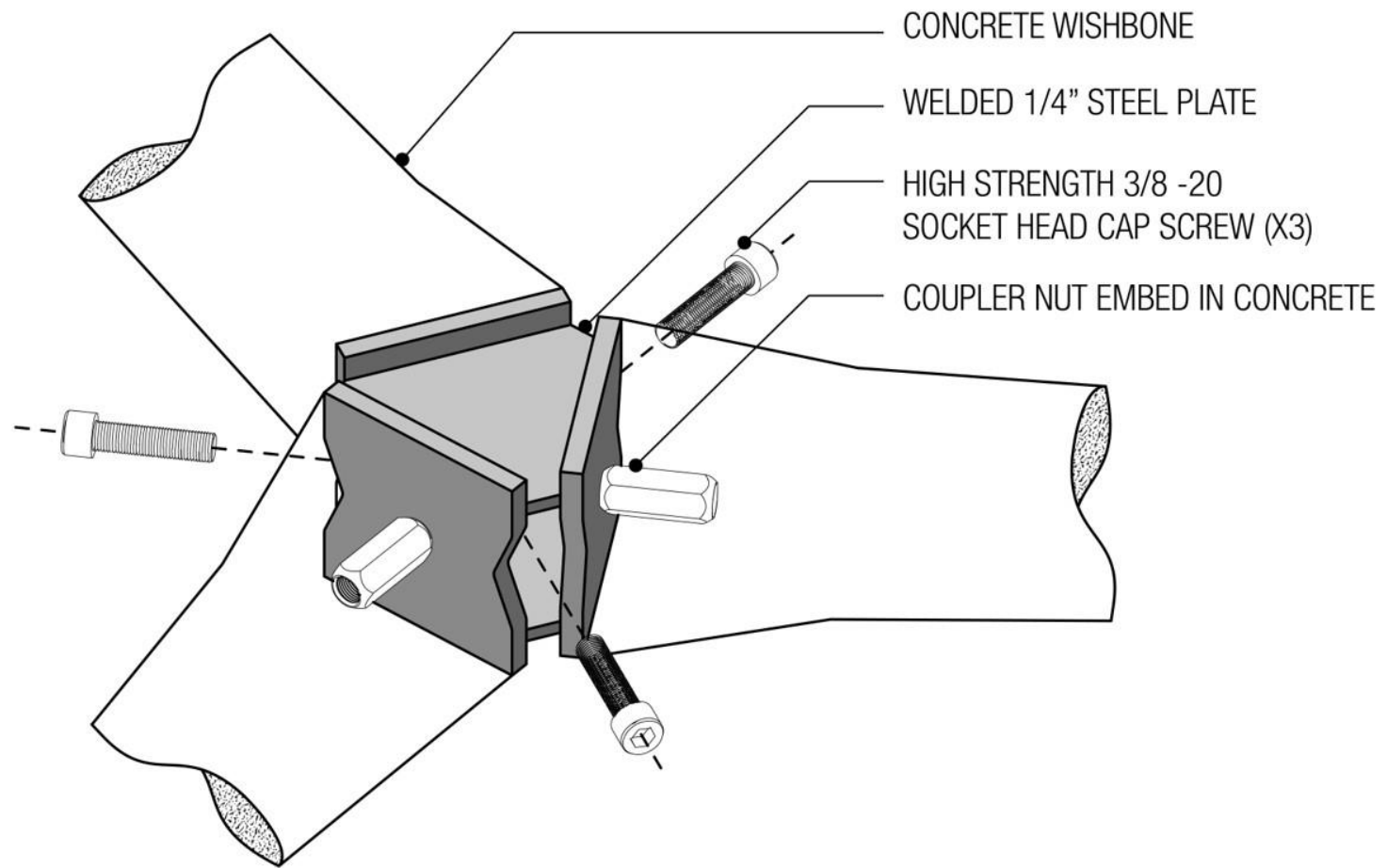





Cement Set/Cure Time

■ Initial Set ■ Cure

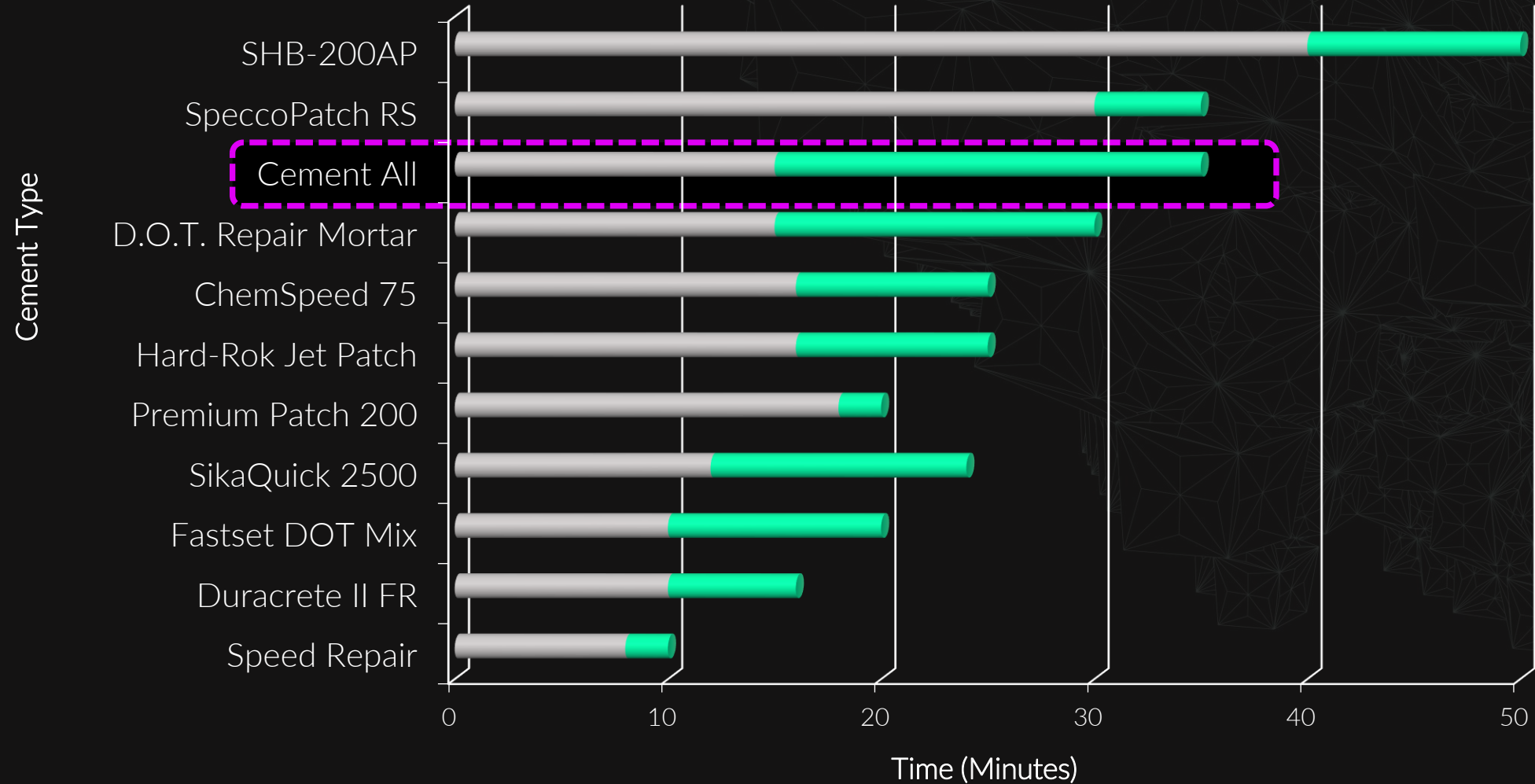



Concrete Strength

■ Cement All ■ Cement All + Helix Steel

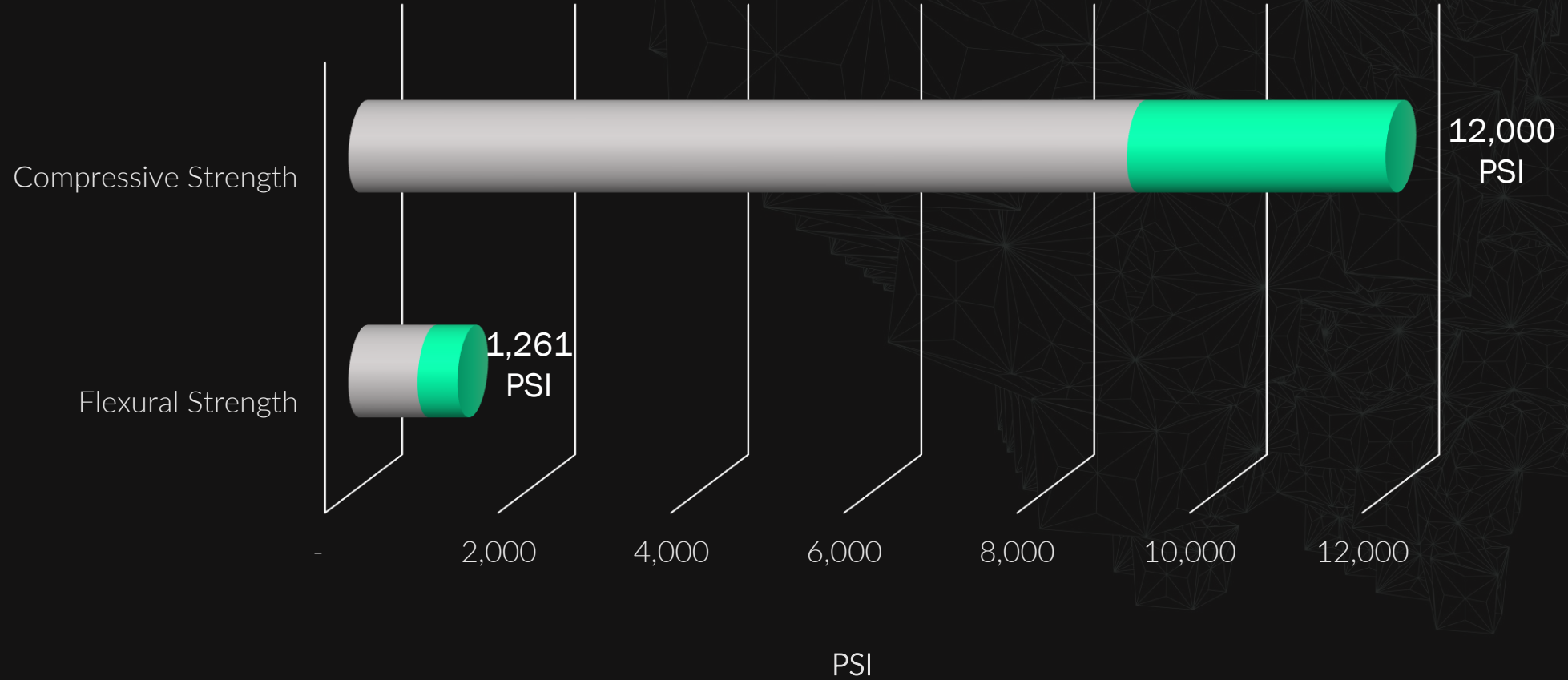















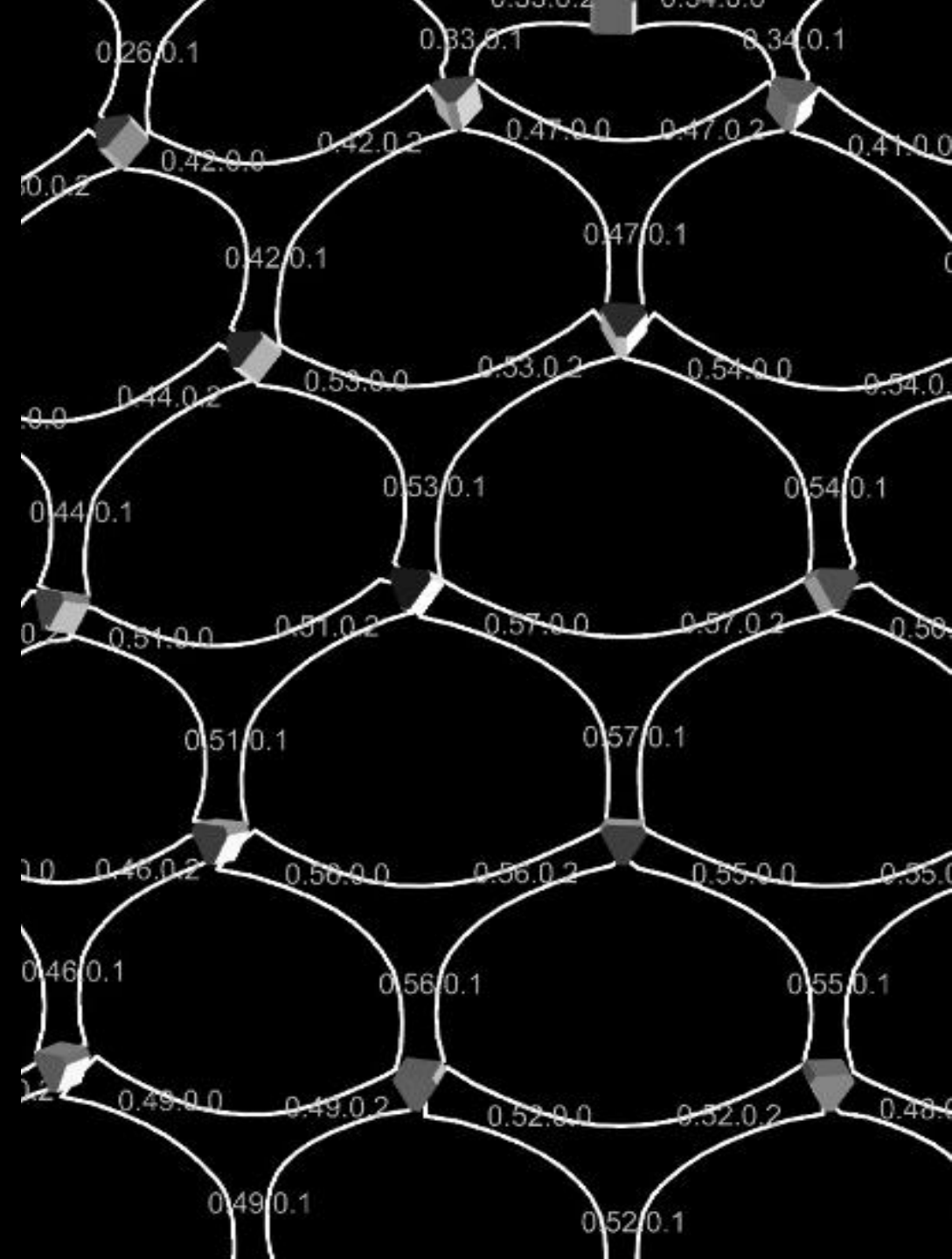
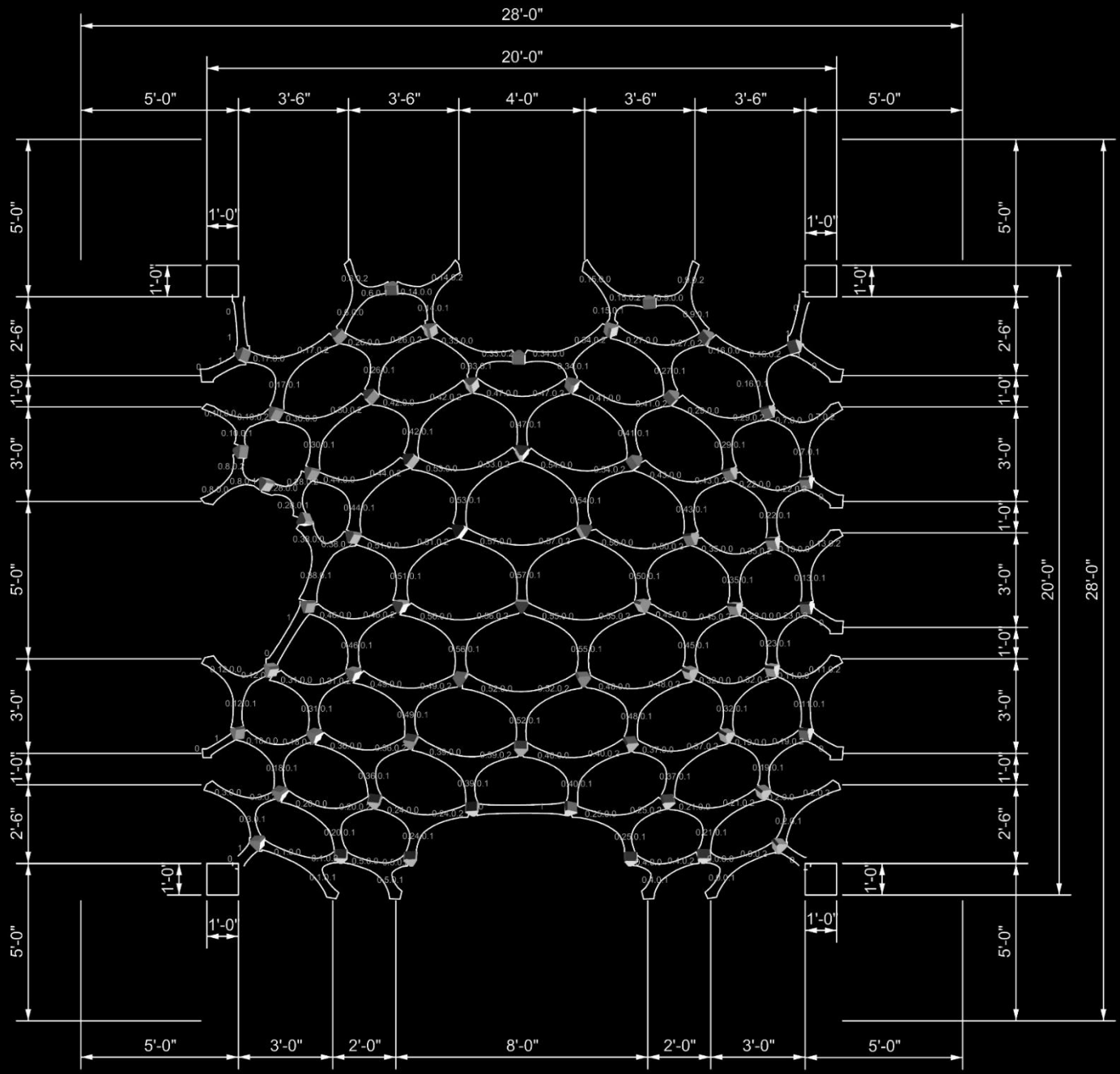



TE

422
CH

INSUL
A
C











amalgamxmusic
A+D Architecture and De... >

Follow



51 likes

honankiruiins traveled a couple thousand light years and found, in a dingy little street, a world where hearts beat to the rhythms of sacred geometry and the color purple. thankful for @ingratoamor for taking this photo and being my travel buddy. 🤩💜 forever thankful for downtown LA and how.. it manages to make me feel like i'm in an entirely different world as an entirely different person every time i visit. pretty sure it spins on its own axis.



contractmag
A+D Architecture and De... > Following

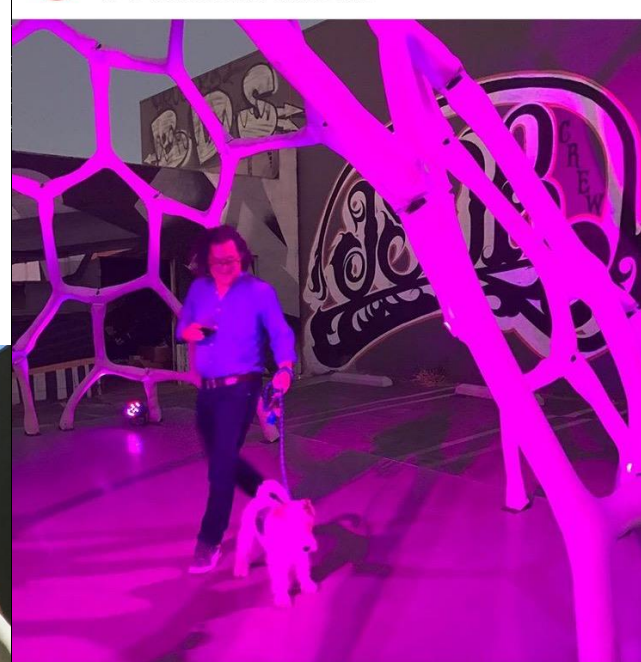

101 likes

contractmag Joey Shimoda (2013 Designer of the Year) of @sdgarc and Bowie 🐶 check out the MARS Pavilion by @formfound_design at @aplusd_la. Photo



bw213
A+D Architecture and De... > Following





CYTOCAST

Costa Mesa
2018

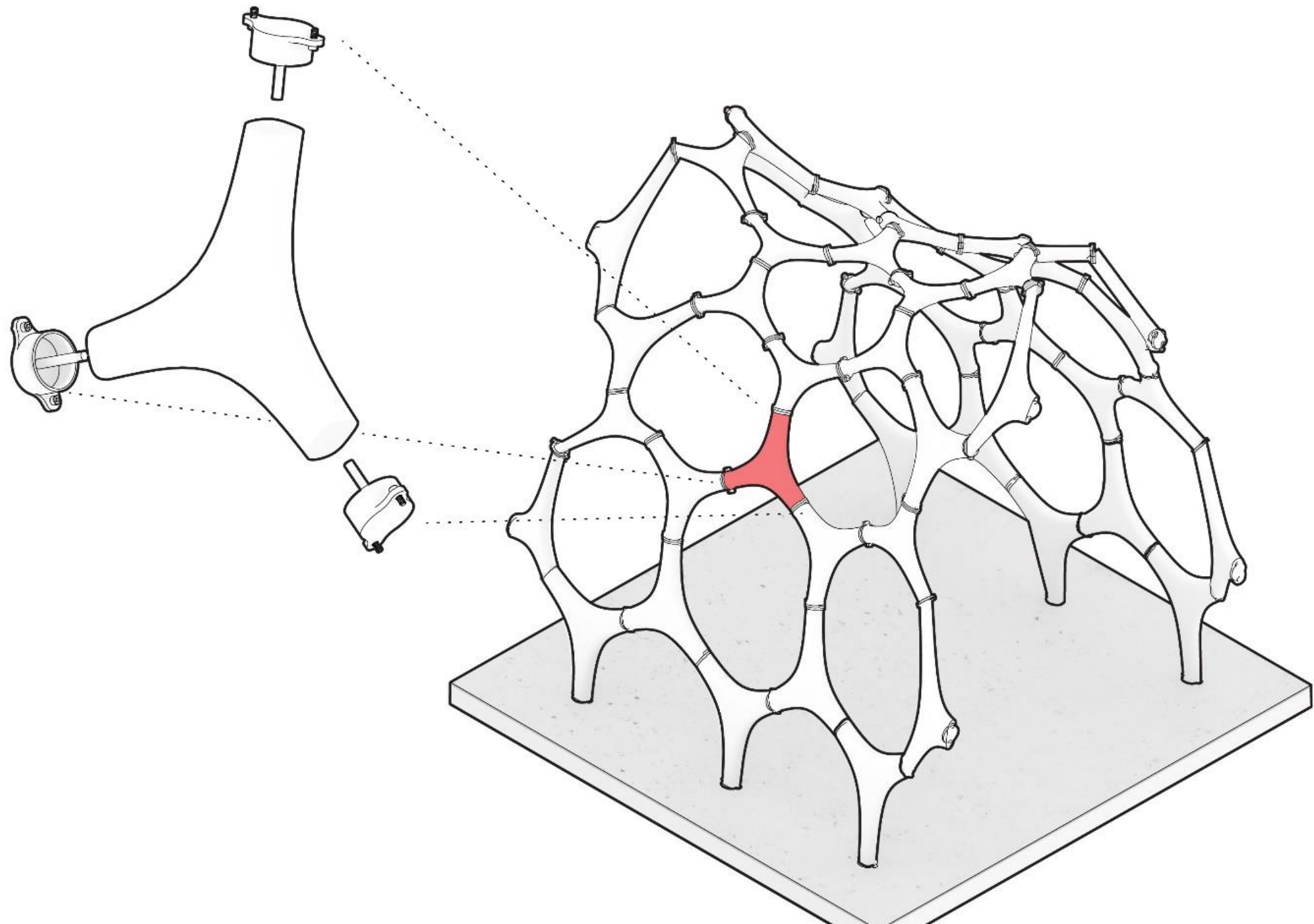

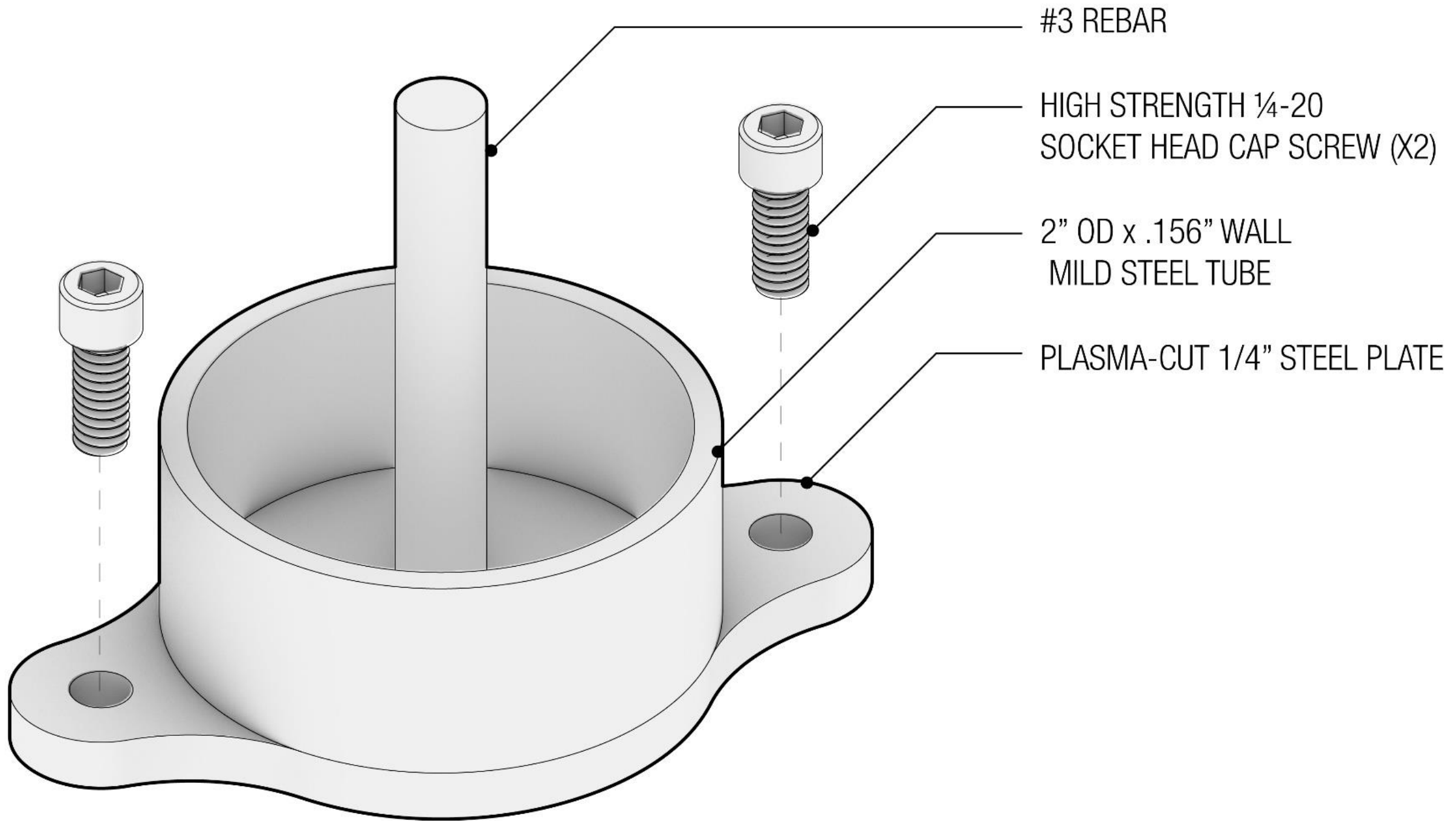







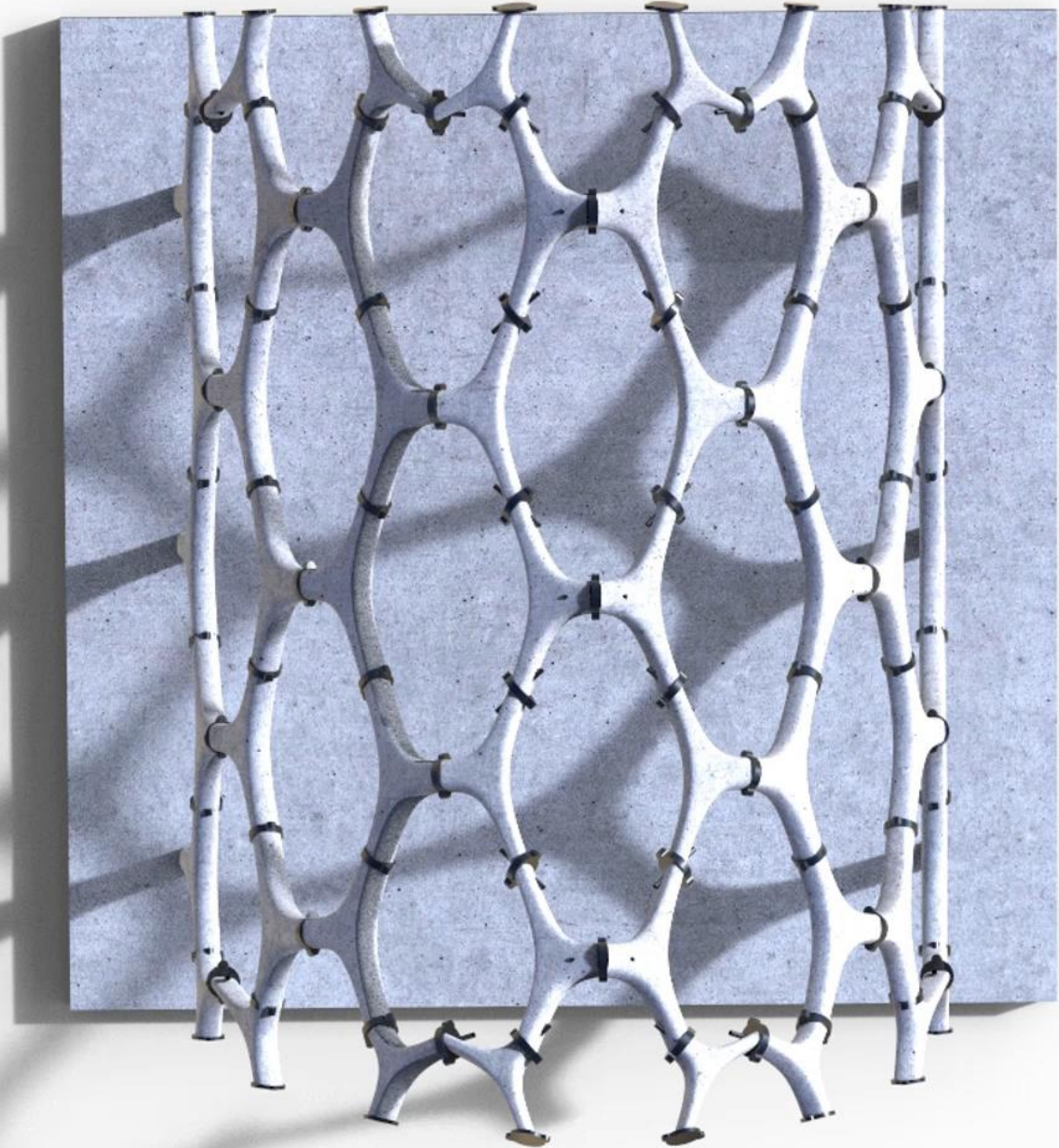







PARAMETRIC TESSELLATIONS

Los Angeles
2019

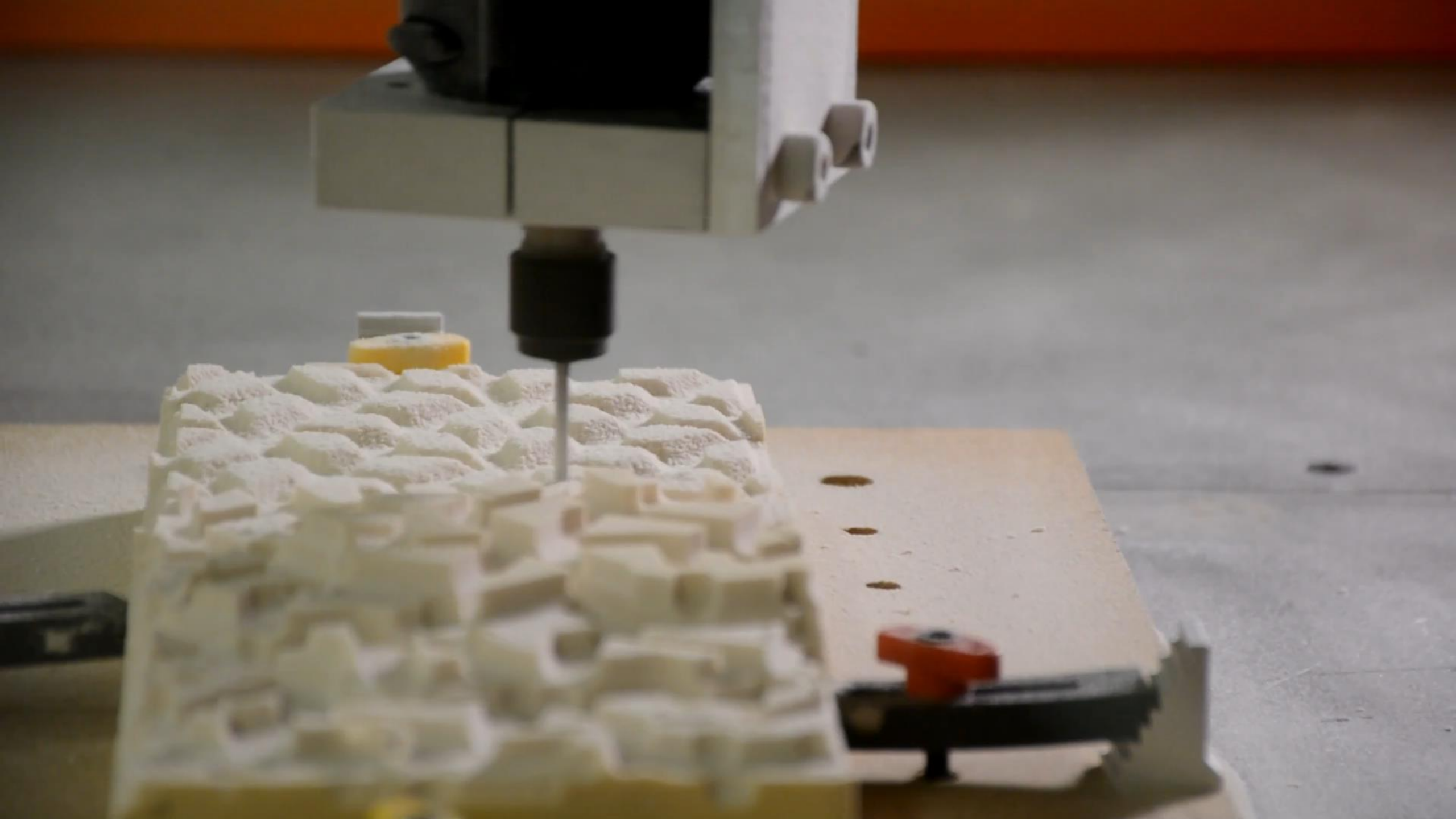

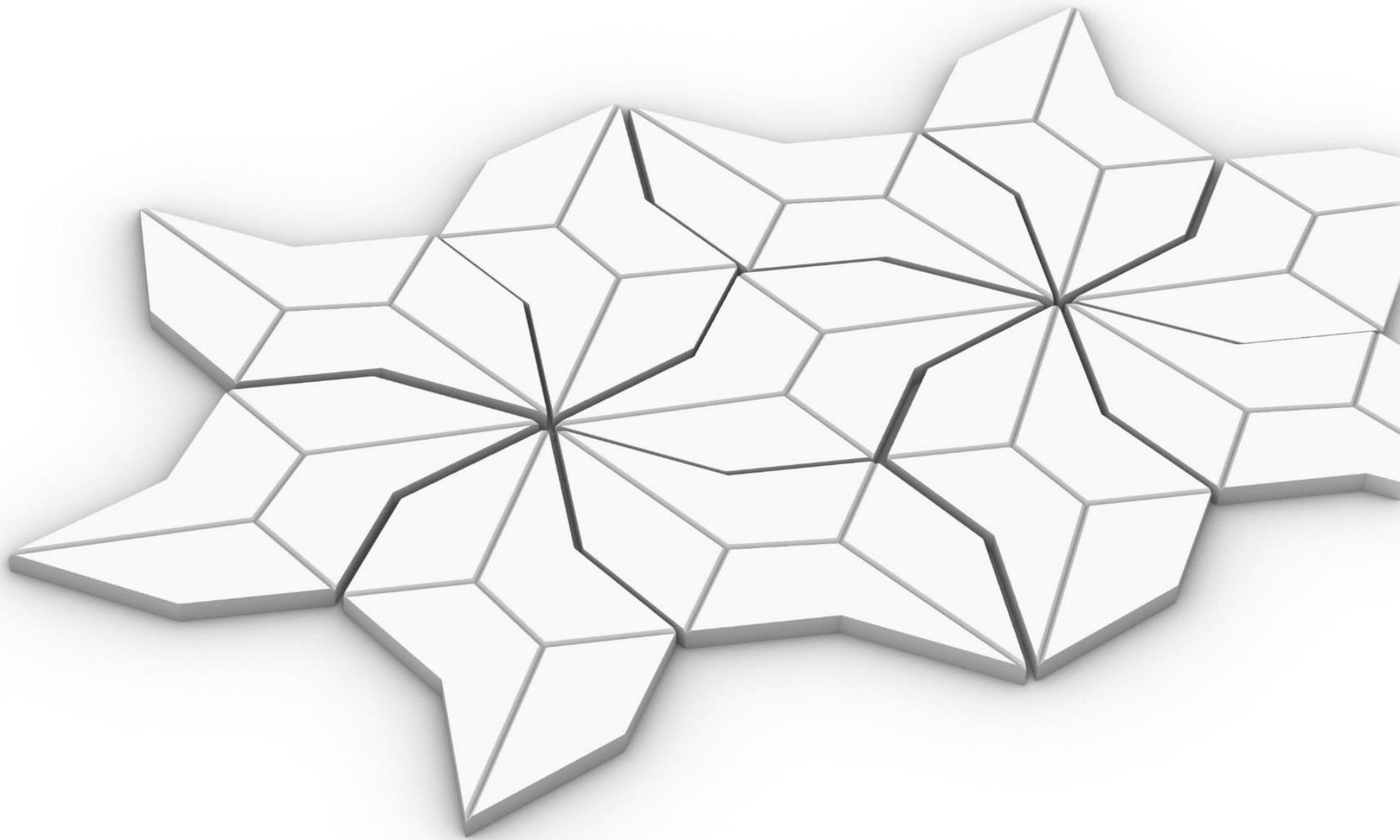



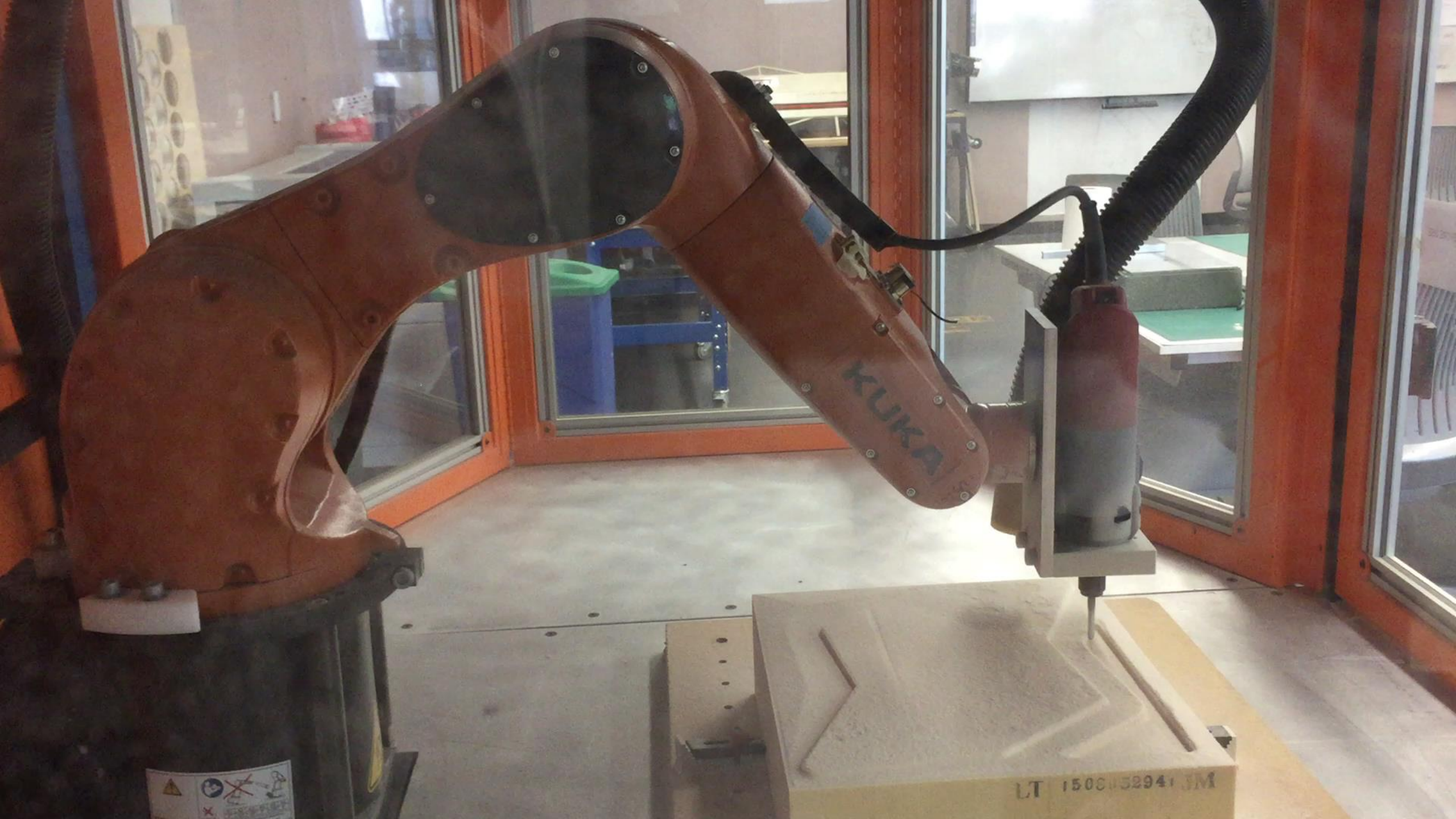

KUKA

LT 1508032941 JM



